

**Instrucciones generales para instalación, uso y mantenimiento
FREIDORAS A GAS**

**Instructions générales pour l'installation, l'utilisation et l'entretien
FRITEUSES A GAZ**

**Allgemeine bedienungssanleitung zur installation, bedienung und wartung
GAS-FRITEUSEN**

**General instructions for installation, use and maintenance
GAS FRYERS**

**Istruzioni generali per l'installazione, l'uso e la manutenzione
FRIGGITRICI A GAS**

Mod:

- FG9-05
- FG9-05S
- FG9-10
- FG7-05

- FG9-05 A
- FG9-05A
- FG9-10 A

- FG7-05
- FG7-10

- FG7-05 A
- FG7-10 A

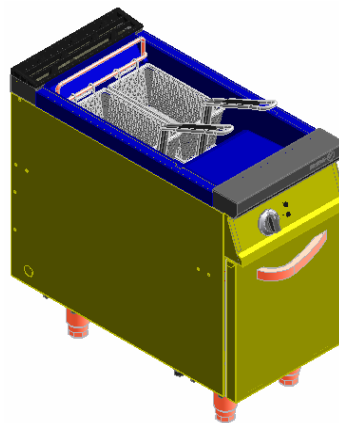

FAGOR 

X166529

FG9-05

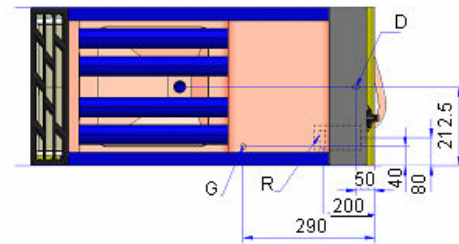
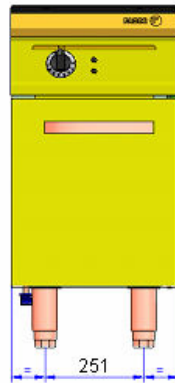
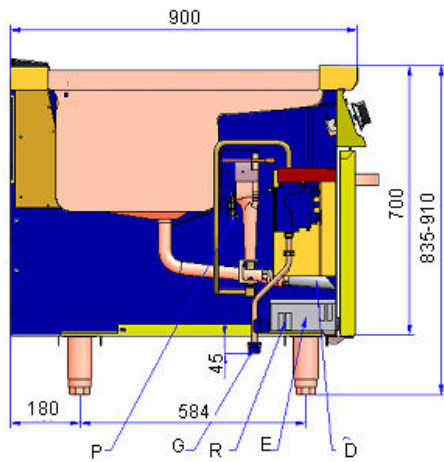

D:Desague
G:Entrada de gas
R:Regleta
P:Pilloto
E:Cuadro electrico

D: Drainage
G: Gas inlet
R: Terminal strip
P: Pilot light
E: Switchboard

FG9-05 S

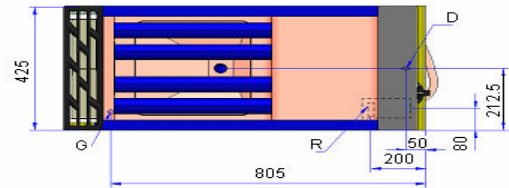
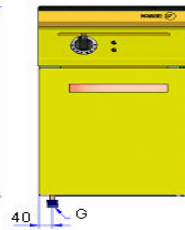
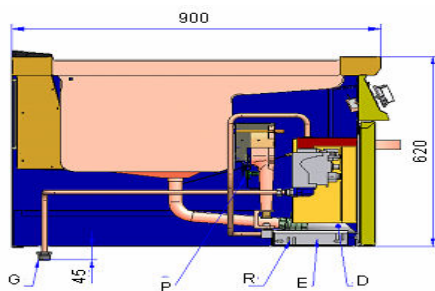

D:Desague
G:Entrada de gas
R:Regleta
P:Pilloto
E:Cuadro electrico

D: Drainage
G: Gas inlet
R: Terminal strip
P: Pilot light
E: Switchboard

FG9-10

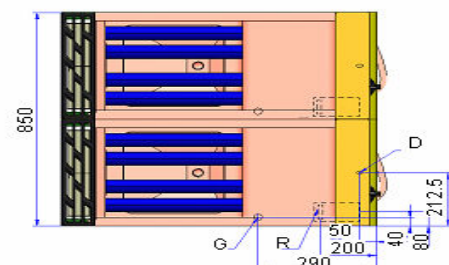
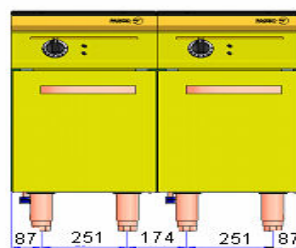
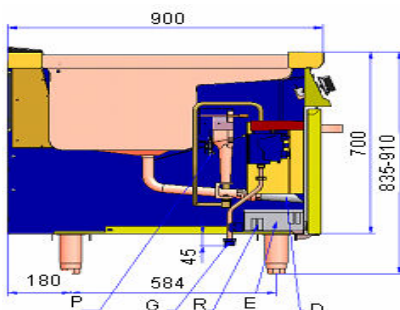

D:Desague
G:Entrada de gas
R:Regleta
P:Pilloto
E:Cuadro electrico

D: Drainage
G: Gas inlet
R: Terminal strip
P: Pilot light
E: Switchboard

FG7-05

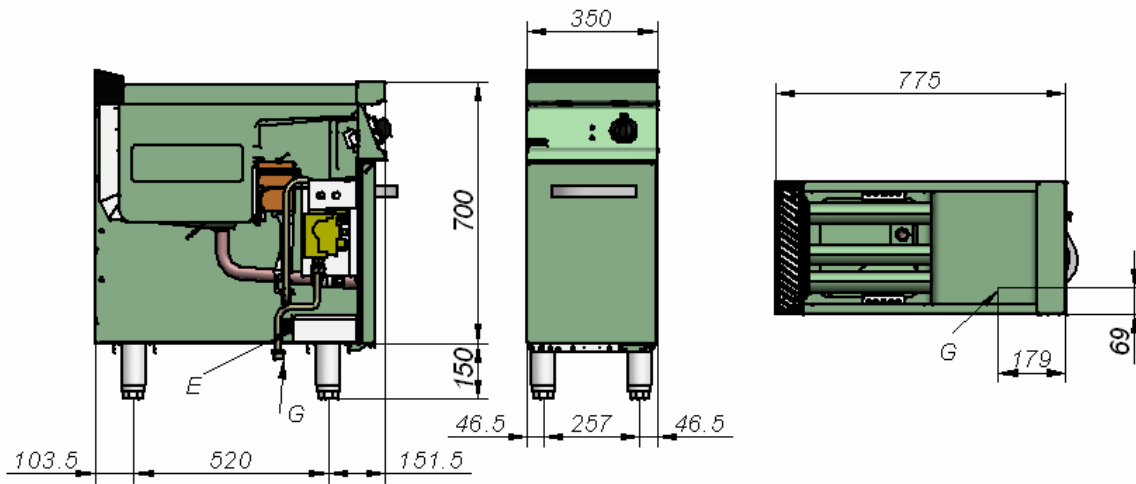

G:Entrada de gas
R:Regleta
E:Cuadro electrico

G: Gas inlet
R: Terminal strip
E: Switchboard

FG7-10

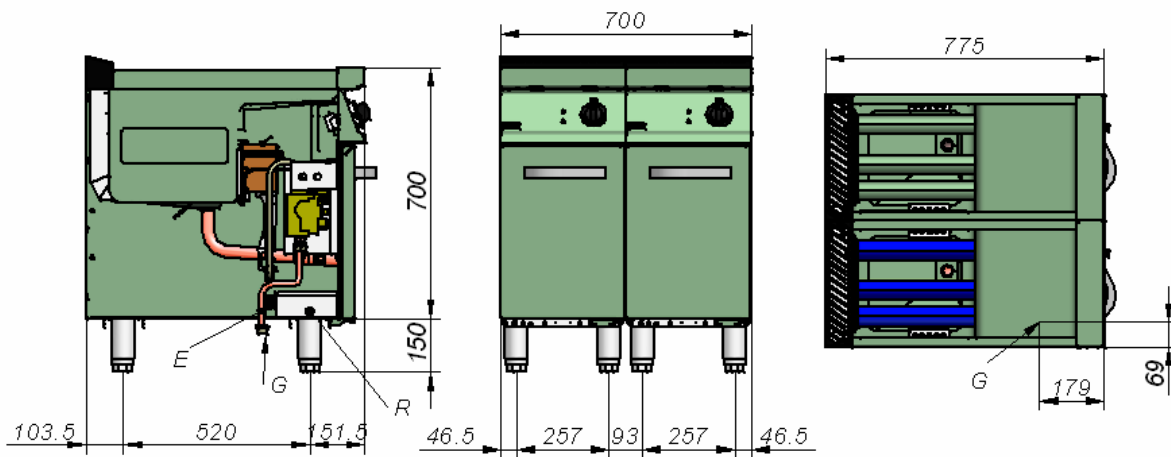

G:Entrada de gas
R:Regleta
E:Cuadro electrico

G: Gas inlet
R: Terminal strip
E: Switchboard

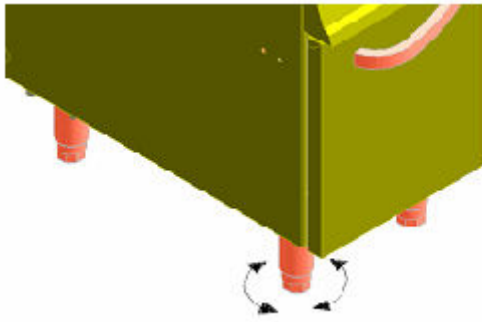

Fig 1

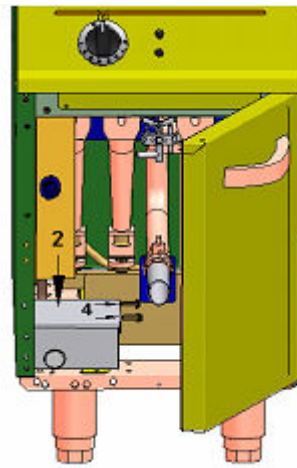

Fig 2

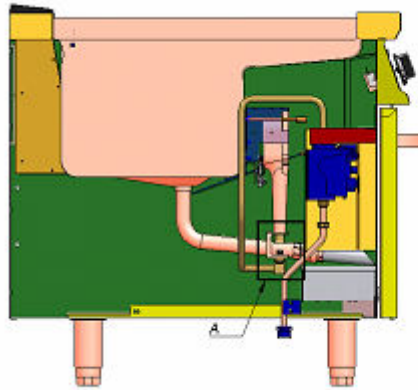
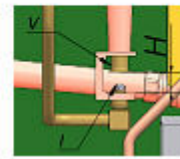

Fig 3



Detalle A

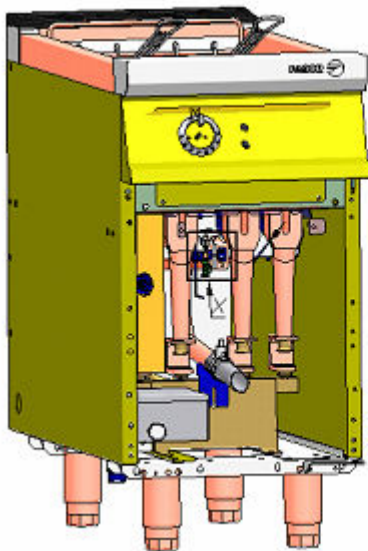
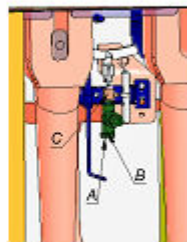

Fig 4



Detalle X

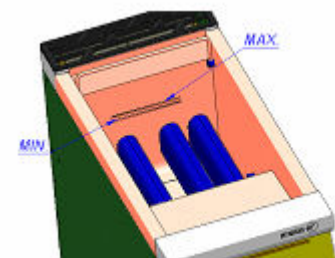

Fig 5

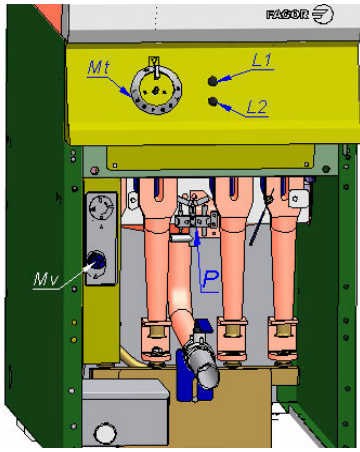

Fig 6

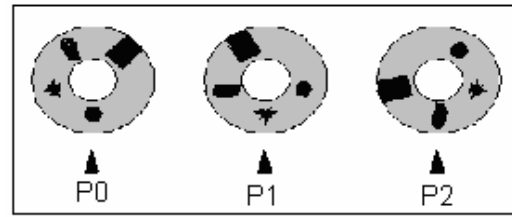

Fig 7

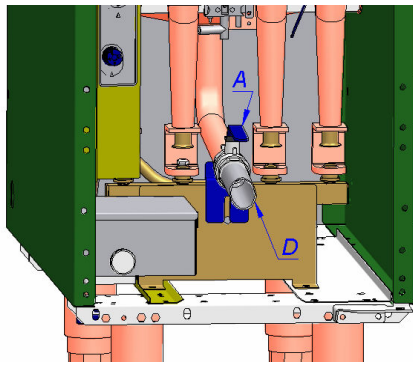

Fig 8

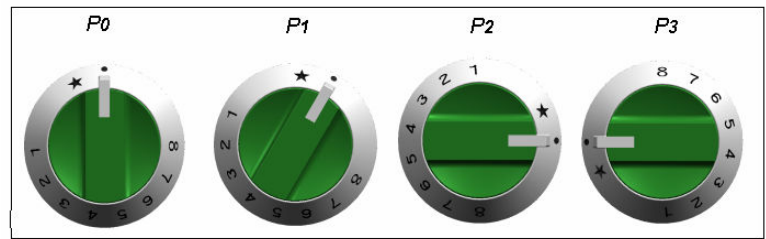

Fig 9

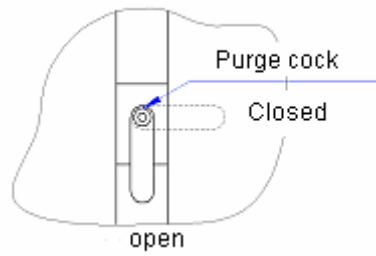

Fig 10

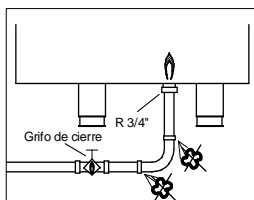

Fig 11

Dear customer

We would like to thank you for the confidence you have shown in our product on purchasing a professional appliance. We are totally convinced that in time you will be completely satisfied with your purchase.

Take a few minutes of your time and get to know the appliance with this instructions manual and "down to work": the easy to understand graphical information replaces pages full of writing.

Nevertheless, we recommend you to read this manual which has been compiled at length by FAGOR's kitchen supervisors, in order to benefit to the maximum from the multiple possibilities and advantages that this appliance offers you.

Keep this manual near to the appliance and at all times in an accessible place.

Lastly, we wish you success and hope that you will be fully satisfied with your new oven.

FAGOR

Index

Installation	
General and connection dimensions	2-3
Technical specifications	7
Positioning and levelling, Electrical connection and Gas Connection, Conversion to different gases and Burner Conversion	12
Pilot light conversion	13
Usage	
Preliminary recommendations	13
Turning the appliance on and burner ignition	13-14
Maintenance	
Maintenance and components	14-15
Environmental protection recommendation	
Environmental protection recommendation	15

Technical specifications (Table n°1)

MODEL		FG9-05	FG9-05 S	FG9-10	
External dimensions	mm	Width	425	425	850
		Depth	900	900	900
		Height	850	620	850
Vat dimensions (internal)	mm	Width	355	355	355
		Depth	250	250	250
		Height	400	400	400
	Capacity	20 l	20 l	40 l	
Net weight (Kg)		79	79	136	
Nominal consumption	m ³ /h	G-110	5,04	5,04	10,08
		G-130	2,97	2,97	5,94
		G-150	3,90	3,90	7,80
		G-20	2,35	2,35	4,70
		G-25	2,73	2,73	5,46
	Kg/h	G-30	1,85	1,85	3,70
		G-31	1,83	1,83	3,66
Nominal calorific consumption	KW/h	L.C.V. (Hi)	22,21	22,21	44,42
	Kcal/h	U.C.V. (Hs)	21,30	21,30	42,60
Total (MJ/h) for Australia	Natural gas		80.0 (MJ/h)	80.0 (MJ/h)	160.0 (MJ/h)
	Propane LPG		80.0 (MJ/h)	80.0 (MJ/h)	160.0 (MJ/h)

MODEL		FG7-05	FG7-10	
External dimensions	mm	Width	350	700
		Depth	775	775
		Height	850	850
Vat dimensions (internal)	mm	Width	302	302
		Depth	345	345
		Height	360	360
	liter	Capacity	15 l	30 l
Net weight (Kg)		50	100	
Nominal consumption	m ³ /h	G-110	3,49	6,97
		G-120	3,10	6,20
		G-130	2,05	4,10
		G-150	2,70	5,39
		G-20	1,59	3,17
		G-25	1,84	3,69
		G-25.1	1,72	3,44
	Kg/h	GZ-35	2,205	4,41
		G-30	1,18	2,36
POWER OUTPUT Kw/h	G-110/G-120/ G-130/G-150		13,50	27,00
	G-20; G-25; GZ-35 ; G-30; G-31		15,00	30,00
	G-25.1		14	28
Total (MJ/h) for Australia	Natural gas		50.0 (MJ/h)	100.0 (MJ/h)
	Propane LPG		50.0 (MJ/h)	100.0 (MJ/h)

Electric installation (Table n°2)

SUPPLY VOLTAGE	CABLE SECTION	POWER SWITCH FUSE	DIFFERENTIAL DEVICE
230V 50-60Hz	2x1,5mm ² +T	4A	30mA
ELECTRICAL OUTPUT KW			0,1Kw

Air consumption (Table n°3)

Mod.	<i>Air consumption necessary for Nm³/h combustion</i>
FG9-05, FG9-05S	25
FG9-10	50
FG7-05	18
FG7-10	36

Approximate positions and temperatures (Table n°4)

Control position	1	2	3	4	5	6	7	8
Temperature	50°C	70°C	90°C	110°C	140°C	165°C	180°C	200°C

Diameter of injectors and adjustment (Table n^o5)

Gas Family		Lower calorific value		G900		G700		
				∅ Injector (mm)	H (mm)	∅ Injector (mm)	H (mm)	
1 ^a	G-110	Kcal/m ³	3.515	3,70	15	3	15	
	G-120							
	G-130		5.960					
	G-150		4.532					
2 ^a	G-20		8.573	1,80	1,7	15		
	G-25		7.372					
	G-25.1		7.000	-				
	GZ-35		5.851	-	2.35			
3 ^a	G-30	28 mbar	Kcal/kg	10.901	1,25	25	1.1	25
		50 mbar						
	G-31	37 mbar						

G-700 FOR AUSTRALIA Model No FG7-05 and FG7-10

GAS		BURNER 700		PILOT
		∅ Injector (mm)	H (mm)	∅ Injector (mm)
Natural Gas	1.0 kPa	1.80	15	0.40
Propane LPG	2.60 kPa	1.20	25	0.25

G-900 FOR AUSTRALIA Model Nos CPG9-05 and CPG9-05S

GAS		BURNER 900		PILOT
		∅ Injector (mm)	H (mm)	∅ Injector (mm)
Natural Gas	1.0 kPa	2.00	15	0.40
Propane LPG	2.60 kPa	1.35	25	0.25

Diameter of pilot's injectors (Table n°6)

Gas Family		Ø(mm)	
1 ^a	G-110	Adjustable	
	G-120	Adjustable	
	G-130	Adjustable	
	G-150	Adjustable	
2 ^a	G-20	0,40	
	G-25	0,40	
	G-25	0,40	
	GZ-35	0,40	
3 ^a	G-30	28 mbar	0,25
		50 mbar	0,20
	G-31	37 mbar	0,25

Country/Categories/Supply pressures (Table n°7)

G-900		
Country of destination	Pressure (mbar)	Categories
AT	20 ÷ 50	II _{2H3B/P}
BE	20/25 ÷ 28/37	II _{2E+3+}
CH, IT	8 ÷ 20, 20 ÷ 30/37	II _{1a2H} , II _{2H3+}
DE, LU	20 ÷ 50	II _{2E3B/P}
DK	8 ÷ 20 ÷ 30	III _{1a2H3B/P}
ES	8 ÷ 20 ÷ 28/37	III _{1ace2H3+}
EE, FI, LT, LV, NO, RO, SI	20 ÷ 30	II _{2H3B/P}
FR	8 ÷ 20/25 ÷ 28/37	III _{1c2E+3+}
CZ, GB, GR, IE, PT, SK	20 ÷ 28-30/37	II _{2H3+}
NL	25 ÷ 30	II _{2L3B/P}
SE	8 ÷ 20; 20 ÷ 30	II _{1a2H} , II _{2H3B/P}
HU	25 ÷ 30	II _{2HS3B/P}
PL	20 ÷ 13 ÷ 30	II _{2ELs3B/P}
MT, CY	30	II _{3B/P}
Australia	Natural Gas	1.0 kPa
Australia	Propane LPG	2.60 kPa

G-700		
Country of destination	Pressure (mbar)	Categories
AT	20 ;50	II2H3B/P
BE	20/25 ; 28-30/37	II2E+3+
DE-LU	20 ; 50	II2E3B/P
DK-SE	8 ;20 ;30	III1a2H3B/P
ES	8 ;20 ;28-30/37	III1ace2H3+
FR	8 ;20/25 ;28-30/37	III1c2E+3+
FI-NO-LT-LV-EE-BG-RO-HR-TR	20 ;30	II2H3B/P
GB -PT-IE-CH-GR-SK-SI-CZ	20 ; 28-30/37	II2H3+
HU	25 ; 30	II2HS3B/P
IT	8 ;20 ;28-30/37	III1a2H3+
MT-CY-IS	30	I3B/P
NL	25 ; 30	II2L3B/P
PL	20 ;13 ;28-30	II2ELs3B/P
Australia	Natural Gas	1.0 kPa
Australia	Propane LPG	2.60 kPa

Different types of gas (Table n°8)

	Kcal/m³								Kcal/kg	
	TOWN GAS				NATURAL GAS				L.P.G	
	G-110	G-120	G-130	G-150	G-20	G-25	G-25.1	GZ-35	G-30	G-31
LOWER CALORÍFIC VALUE	3.515	3.950	5.960	4.542	8.573	7.372	7.000	5.851	10.901	11.066

1.-INSTALLATION

Positioning and levelling

The positioning and electrical and gas installation should always be carried out by an AUTHORISED TECHNICIAN, observing the standards of each country. (For Australia AS 5601 and local authority).

It is advisable to install an extraction hood for the optimum operation of the appliance. All appliance transit protection must be removed.

Put the appliance in a sufficiently ventilated room, in accordance with the current regulations, to prevent the formation of unacceptable concentrations of harmful substances in its installation site. Clearance from combustible material is 100mm from side & rear and 1000mm from overhead.

IMPORTANT: Except when indicated otherwise, the parts that must be protected by the manufacturer must not be manipulated by the installer.

Level and adjust the height of the appliance. (Fig. 1)

Electrical connection

The appliance's electrical connection should always be carried out by an AUTHORISED TECHNICIAN.

The legal standards in force in each country on connections to the mains should be taken into account.

Check that the mains voltage corresponds to that indicated on the name plate.

Use cable sleeves made out of polychloroprene or other similar materials (H05RN-F), for the connection.

Put an autonomous power switch with fuses into the mains socket, with a minimum distance between contacts of at least 3 mm.

It is obligatory to earth the appliance. The manufacturer takes no responsibility if this requirement is not fulfilled.

The section of cable sleeve and the rating of the fuses to be installed in the power switch are indicated in table no. 2.

To access the appliance's electrical connection terminal strip (see fig 2), loosen the screws (4) on the lid of the switchboard (2). Pass the cable sleeve through the stuffing box located in the switchboard and connect it to the terminal strip.

VERY IMPORTANT: Before putting the switchboard top on, fasten the electric supply cable tightly to the stuffing box.

When several appliances are installed in series, they should be earthed to each other using the point assigned for this purpose, located in the rear part of the appliance.

Gas connection

The general installation should have a stop-cock and a pressure regulator and it is also advisable to install a shut-off cock on each individual appliance.

A tube of at least Ø 12 x 10 mm should be used for the appliance's gas connection, along with a ¾" nut to put the fryer together Fig. 1- Fig. 1 bis

The installer must test the operation of the appliance after installation. Contact your supplier if the appliance cannot be adjusted to perform correctly.

Conversion to different gases

If the appliance is prepared for a different type of gas to the one available, you should proceed as follows:

Cut off the gas to the appliance if connected. (All conversions of the appliance's gas circuit must always be carried out by a QUALIFIED/AUTHORISED TECHNICIAN).

Burner conversion

Injector replacement.

Dismantle the burners' "I" injectors (Fig. 3) and replace them with suitable ones depending of the gas to be used (Table 5)

Burner air adjustment.

Set the air regulator "R" (Fig. 3) to the "H" measurement (Table 5) depending on the gas to be used.

Pilot light conversion

To convert to NATURAL GAS, please proceed as follows: Loosen screw "A" of the Fig. 4.

The 0.25 mm injector "B" is underneath screw "A", which must be loosened and replaced by the 0.40 mm injector supplied with the nozzles.

Turn the air regulator "C" until the flame steadies, fig 4.

To convert to TOWN GAS, the adjustment of the pilot flame will be carried out turning the adjusting screw "B" until the flame is stable.

After adapting the equipment to another type of gas or to another pressure, other than that for which it had been previously set, the old instructions should be replaced with the instructions for the new settings, to enable unambiguous identification of the state of the equipment after modification.

2.-USAGE

Preliminary recommendations

It is advisable to call a qualified installer to install the appliance and if necessary, adapt it to use other types of gas.

This appliance is only for professional usage and must be used by qualified personnel.

IMPORTANT: The parts protected by the manufacturer must not be manipulated by the installer and or user.

USAGE RISKS:

You are using a fryer, do not use this appliance for anything other than what it is designed for, as its operating components may be damaged.

Frequently check the tubs' filling level.

- It if is insufficiently filled the oil may get too hot causing the appliance to overheat.
- Too much oil may cause the hot oil to spill out with the subsequent risk of burns.

Try not to fill it up with oil when the fryer is hot, as it could cause the oil to splash out.

Avoid putting wet food into the fryer or water in the oil or hot fat, as oil may splash causing serious burns.

If you are going to use solvents or inflammable clearing products to remove the possible dirt on the tub, always do so when the fryer is cold, the control buttons off, and the gas tap closed. Once the products have been used, carefully clean it the tub with plenty of water.

Warning: Do not spray aerosols in the vicinity of this appliance while it is in operation.

Turning the appliance on

IMPORTANT: Never start up the appliance without having previously filled the vat, otherwise overheating would seriously damage the machine.

The oil should be filtered regularly, in order to preserve it better.

Replace the oil when it reaches the MINIMUM level (Fig. 6).

It is recommended to insert the loaded basket in the oil slowly so that the oil froth resulting from frying does not boil over the upper part of the vat.

Burner ignition

Open the main general gas-tap installed on the outside of the appliance.

1st Step Pilot Light Ignition

Turn the thermostat Mt control (Fig. 6) clockwise until the pilot light position ★ (Fig. 8 - P1), at this moment the “L1” lamp will light up (Fig. 6) indicating that it is ready for the “P” pilot light to be ignited (Fig. 6).

Next, press the solenoid valve Mv control (Fig. 6), whilst turning anti-clockwise to the pilot light position ★ (Fig.7 - P1). In this position, keep pressing the control until the “P” pilot light flame (Fig. 6) is permanently lit (approximately 20 seconds).

2nd Step Ignition of burners

Pressing the solenoid valve control Mv (Fig. 6), rotate to burners ignition position (Fig. 7 - P2), it is ready for the burners to be ignited.

To ignite the burners, press and turn the thermostat “Mt” control (Fig. 6) clockwise until the required position, (Fig. 8, P2 and P3). At this moment the “L2” lamp will light, indicating that the burners are functioning.

The required oil temperature (approximate) can be achieved turning the “Mt” control to selected position (see table 4 for temperatures, indicating the temperature corresponding to each position on the control).

When the oil in the vat reaches the selected temperature, the burners will turn off by means of the thermostat (lamp “L2” turns off). Also, as soon as the temperature drops below the selected value, the burners will light up (switching on the L2 lamp).

Turning the burners off

Move from the position selected on the “Mt” control to the pilot light position (Fig. 8 – P1), so that only the “P” pilot light is on (Fig.6)

Turning the pilot light off

Move the “Mv” control to the “0” position (Fig. 8 –P0) and also move the “Mt” thermostat control to the “0” position (Fig7. – P0)

3.-MAINTENANCE

Service

Annual service to this appliance is recommended. For any minor adjustments, fault finding, or if this appliance cannot be adjusted to operate correctly, contact the Fagor Service Department. Service work must only be carried out by authorised service personnel.

For Australian service and parts contact: Fagor Australasia Pty Ltd. 7 Boola Place, Dee Why, NSW 2099. Ph 02 99847533 Fax 02 99847533 Email info@fagor.com.au

Initial cleaning

After installing the appliance, and before filling the vat with oil, it is necessary to fill it with soapy water, which should be left to boil for a few minutes. Next, empty the vat and rinse it as many times as necessary, to eliminate the remains of soap.

Daily cleaning

In order for the appliance to work as new, it is advisable to follow the following instructions:

Do not use gritty and abrasive detergents for cleaning.

Do not use a water hose to clean the appliance.

It is advisable to regularly clean the inner part of the vat with soapy water that will be left to boil for a few minutes, and then rinse it with plenty of water.

It is important that as soon as the vat has been cleaned and before filling it with oil, it be completely dry without a sign of water.

List of spare parts

Gas valve	Thermocouple
Burner	Thermostat
Pilot burner	

IMPORTANT NOTE:

It is vital that the flue pipe does not become blocked, not even partially, for the proper functioning of the burners.

A check is recommended to be carried out at least once a year by an AUTHORISED TECHNICIAN, on all the fryer's components to check their operating condition and the proper operation of the appliance.

The replacement of any functional component that can affect the safety of the appliance must be carried out by an AUTHORISED TECHNICIAN.

As a general rule, whenever an operating component is replaced, you must check that the main gas-tap is shut and that there is no fire in the vicinity of the appliance.

4.-ENVIRONMENTAL PROTECTION RECOMMENDATION



On ending its useful life, this product must not be thrown away in a standard rubbish bin, but must be left in a electrical waste and electronic equipment collection point for recycling.

This is confirmed by the symbol on the product, user manual or packaging.

Depending on the symbol, the materials can be recycled. By recycling and other ways of processing electrical waste and electronic equipment, you can significantly contribute to protecting the environment.

Contact your local authorities for more information of the nearest collection point.

To conserve the environment at the end of the useful life of your product, leave it in the appropriate places in accordance with the current legislation.

**This appliance is only for professional usage and
can only be used by qualified personnel**

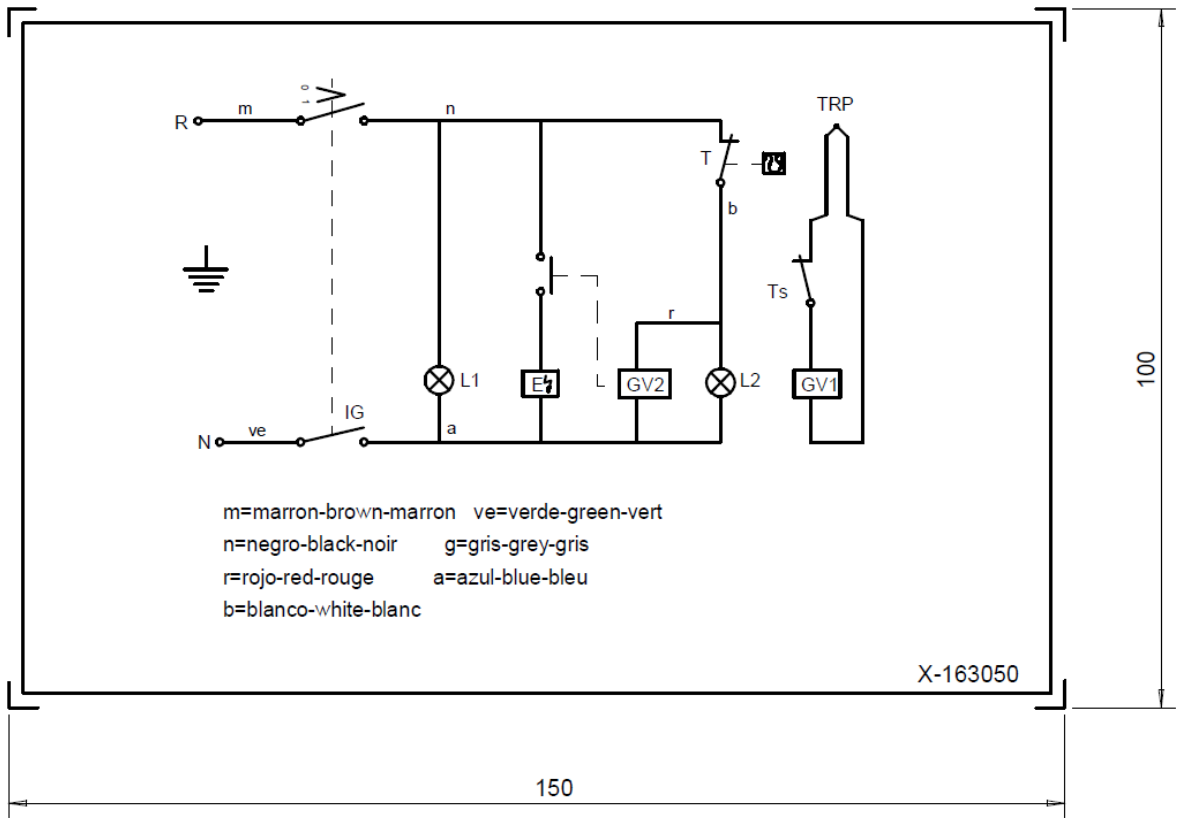

NOTA

- LAS INSCRIPCIONES RESISTIRAN SIN MODIFICACION APRECIABLE, EL FROTAMIENTO DURANTE 15 SEG. DE UN ALGODON EMPAPADO EN GASOLINA.

- IG = Interruptor general
- L1 = Lampara funcionamiento
- T = Termostato regulable (60-220C)
- Ts = Limitador (245)
- L2 = Lampara calentamiento
- E = Encendedor
- GV1 = Valvula gas (SEGURIDAD) ①
- GV2 = Valvula gas (CONTROL) ①
- TRP = Termopar

Plastico blanco alto brillo

Esquema teorico adhesivo FG-920 A		X-163050			
Nº	Pieza	Material	Nº Clasificacion	Acabado	
Nº	Modificacion	Propuesta de	Fecha	Tolerancias generales	
①	Pasar de GV y VG a GV1 y GV2	Letona	97-1-16	$< 5 \pm$ $50-100 \pm$: $5-25 \pm$ $> 100 \pm$ $25-50 \pm$ $\infty \pm$	
2	Modific.general(pasar a fabric.interior)	Plazaola	97-4-23		
Dibujado	Firma	Fecha	 Fagor Industrial, Koop. Elk, Mugatua		Mecanizado superficial
Proyectado	JON	96-5-30			
Comprobado	<i>to g</i>				
Escala	FREIDORAS			Plano numero HB-70479 -2	
Plano hau ez daiteke erabil ez berzia gure baimentiz gabe				Sustituye al N°	
				Sustituido por	