

**INSTRUCCIONES GENERALES PARA EL
MONTAJE DE LA MESA DE SALIDA DE 90°**

**INSTRUCTIONS GÉNÉRALES POUR LE
MONTAGE DE LA TABLE DE SORTIE À 90°**

**GENERAL INSTRUCTIONS FOR THE ASSEMBLY
OF THE 90° EXIT TABLE**

**ALLGEMEINE ANWEISUNGEN ZUM
EINBAU DES 90°-AUSLAUFTISCHES**

**ISTRUZIONI GENERALI PER IL MONTAGGIO
DEL TAVOLO DI USCITA A 90°**

Z-312517

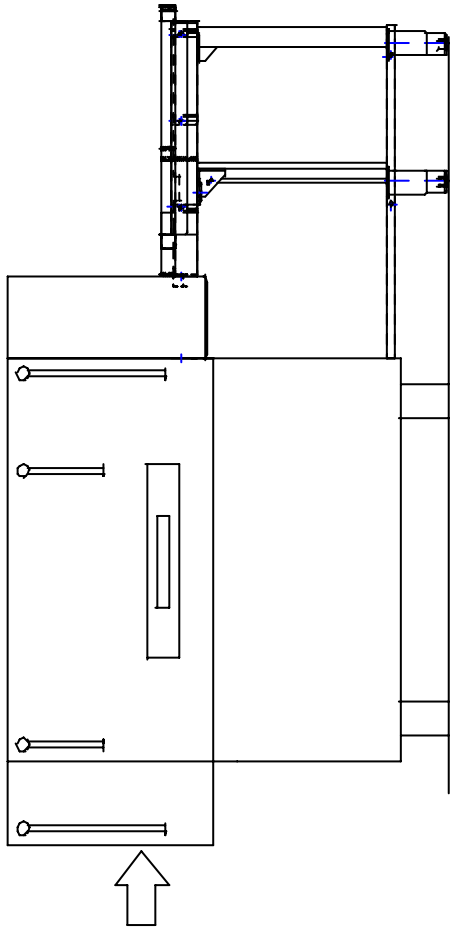

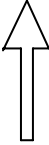
Frente del aparato 

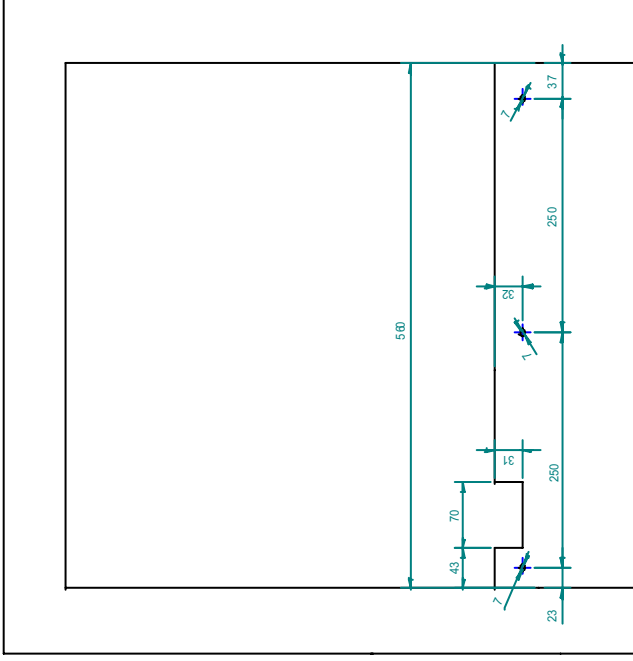

Salida del aparato en alzado (versión Izda.)

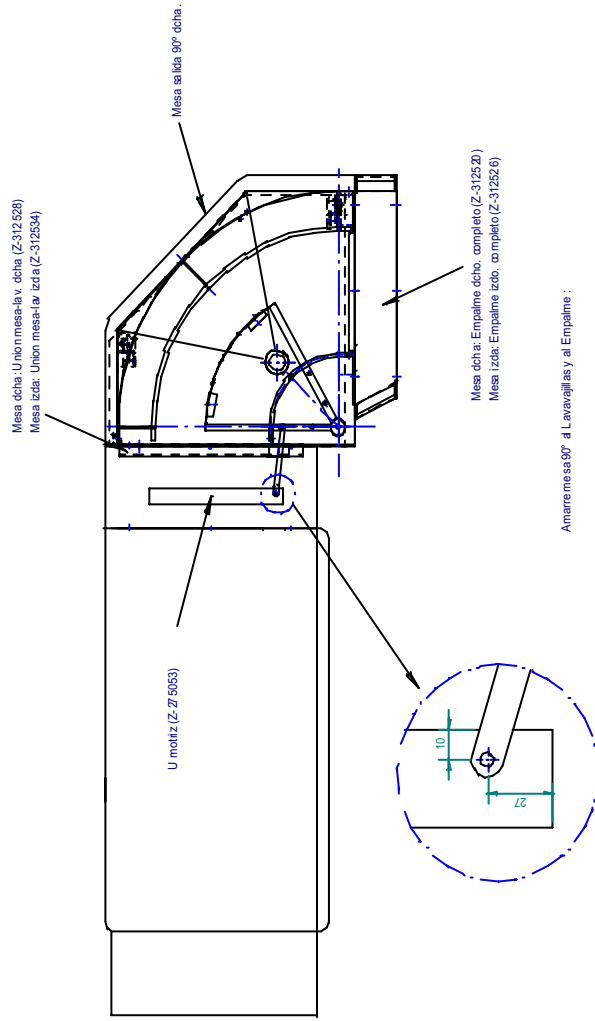

INSTRUCCIONES PARA EL MONTAJE DE LA MESA DE 90°

LADO INFERIOR DE LA MESA

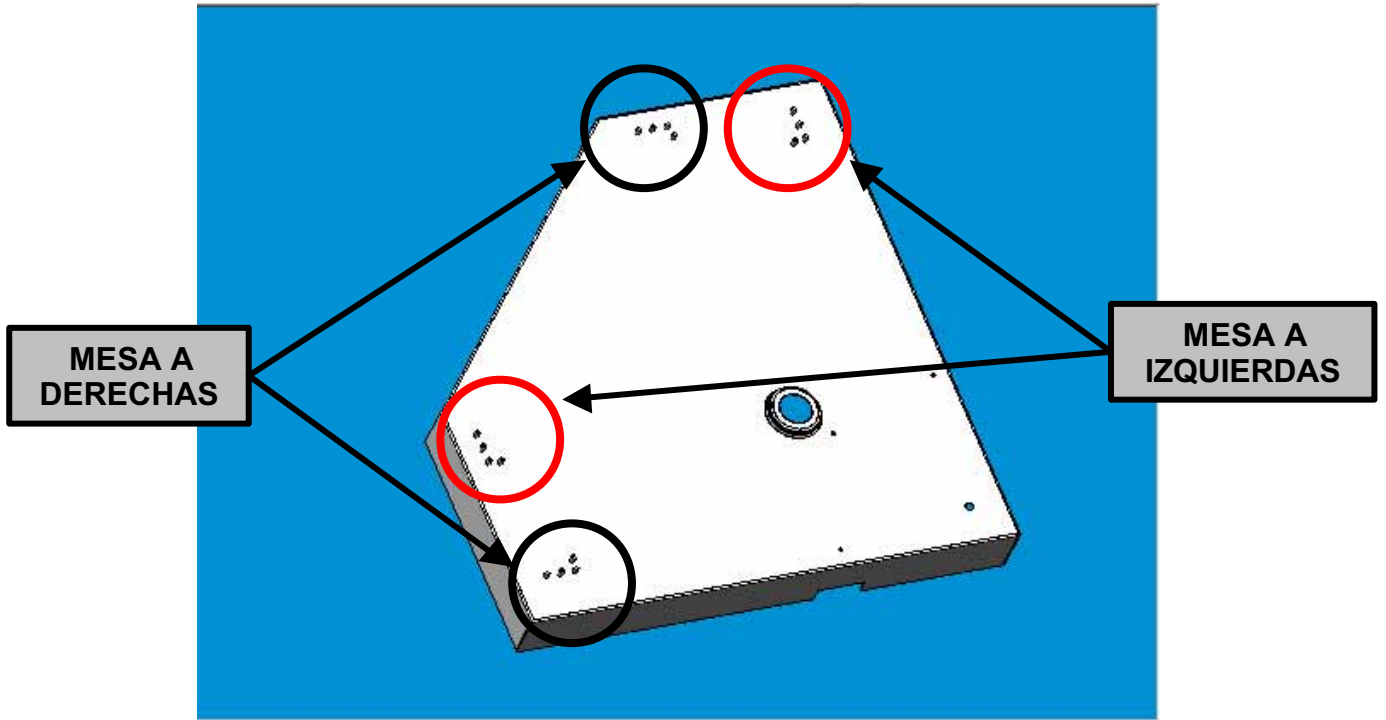

LADO SUPERIOR DE LA BANDEJA

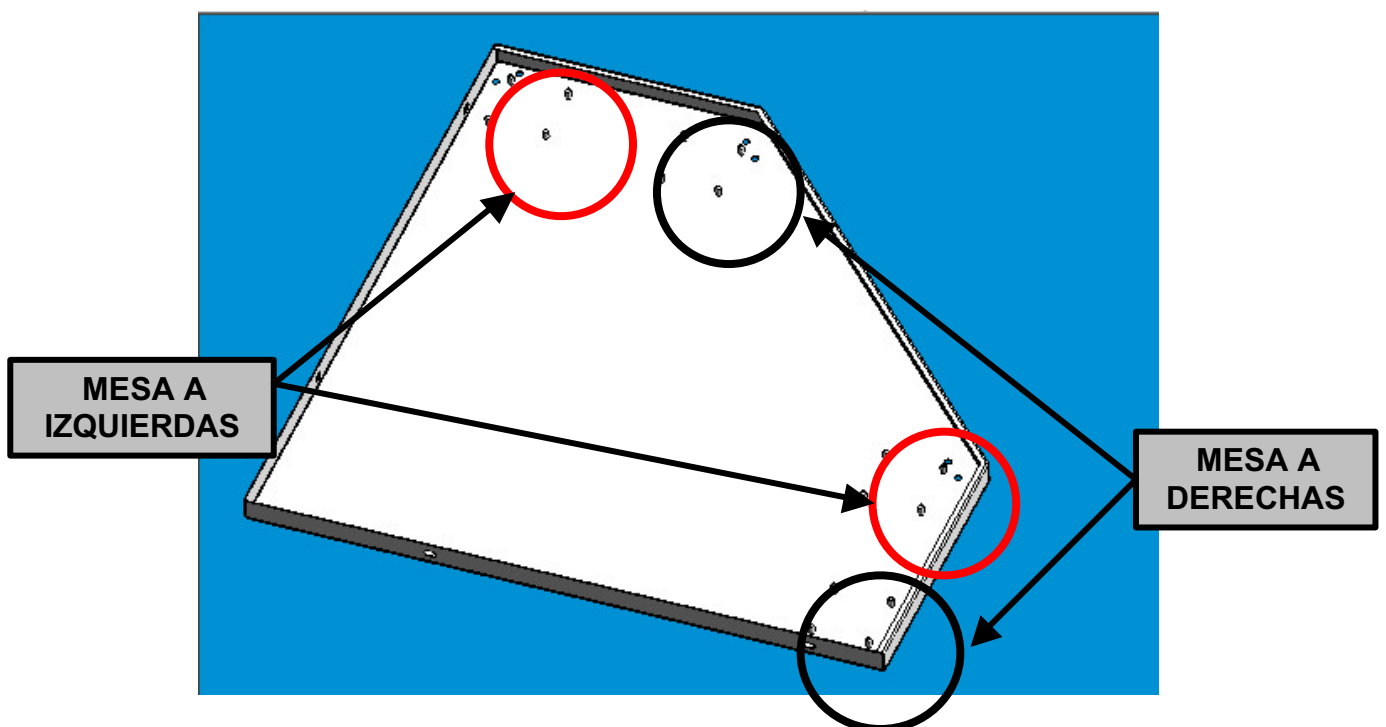

POSICIONAMIENTO DE LOS PERNOS DE LA UNION DE LAS PATAS CON LA MESA DEL LAVAVAJILLAS DE 90°

SIN TUNEL DE SECADO

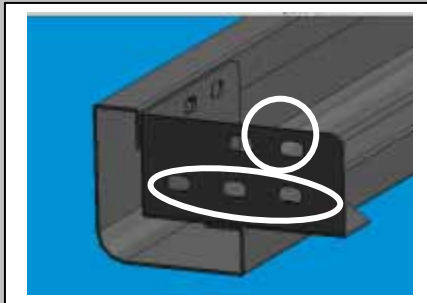
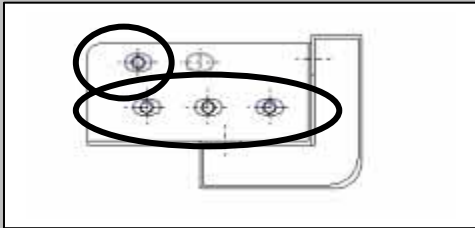

CON TUNEL DE SECADO

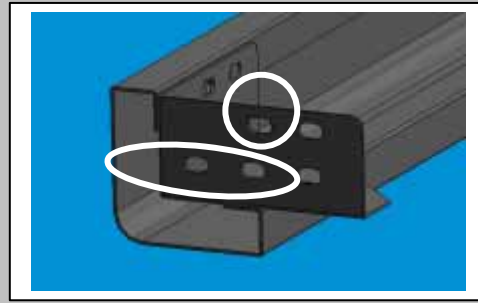
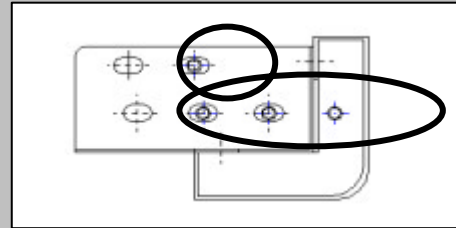

LISTA DE PIEZAS INCLUIDAS EN EL KIT DE INSTALACIÓN DE LA MESA DE 90°

REF.	DENOMINACIÓN	DCHA. T.S. 1210309007	DCHA. 1210309009	IZDA. T.S. 1210309008	IZDA. 1210309010
Z312500000	MESA 90° DCHA COMPLETA	1	1	-	-
Z312504000	PATA MESA 90° COMPLETA	2	2	2	2
Z312519000	AMARRE PATA MESA 90°	2	2	2	2
Z312520000	EMPALME DCHO. 90° COMPLETO	1	1	-	-
Z702101000	TUERCA R.11/2 DERLIN	1	1	1	1
Z312506000	BANDEJA COMPLETA. 90° DCHA.	1	-	-	-
Z312529000	BANDEJA COMPL. T E/S 90° DCHA.	-	1	-	-
X260151000	PATA REGULABLE	2	2	2	2
Z312528000	UNION MESA- LAVAVAJ. DCHA.	1	1	-	-
Z312539000	BARRA IMPULSIÓN 90°	1	1	-	-
Z272583000	SUPLEMENTO DCHO. MESA 180°	1	1	-	-
Z312517000	INSTALACIÓN MESA 90°	1	1	1	1
Z312503000	MESA 90° IZDA. COMPLETA	-	-	1	1
Z312526000	EMPLAME IZDO. 90° COMPLETO	-	-	1	1
Z312507000	BANDEJA COMPLETA 90° IZDA.	-	-	1	-
Z312531000	BANDEJA COMPL. T E/S 90° IZDA.	-	-	-	1
Z312534000	UNION MESA-LAVAVAJ. IZDA.	-	-	1	1
Q032041000	TORN. ALOM. M6X10	5	5	5	5
Q232040000	ARANDELA A6	7	7	7	7
Q262040000	ARAND. GROW. A6 A 304	7	7	7	7
Q212040000	TUER. SOMBR. M6	5	5	5	5
Q242030000	ARAND. ABAN. A5 A 304	8	8	8	8
Q012031000	TORN. EXA. M5X10 A304	8	8	8	8
Q232050000	ARANDELA A8	4	4	4	4
0120430000	TORN. EXA. M6X20 A 304	4	4	4	4
Q262040000	ARAND. GROW. A6 A 304	4	4	4	4
Q212040000	TUER. SOMB M6	4	4	4	4

INSTRUCTIONS GÉNÉRALES POUR LE MONTAGE DE LA TABLE À 90°

CÔTÉ INFÉRIEUR DE LA TABLE

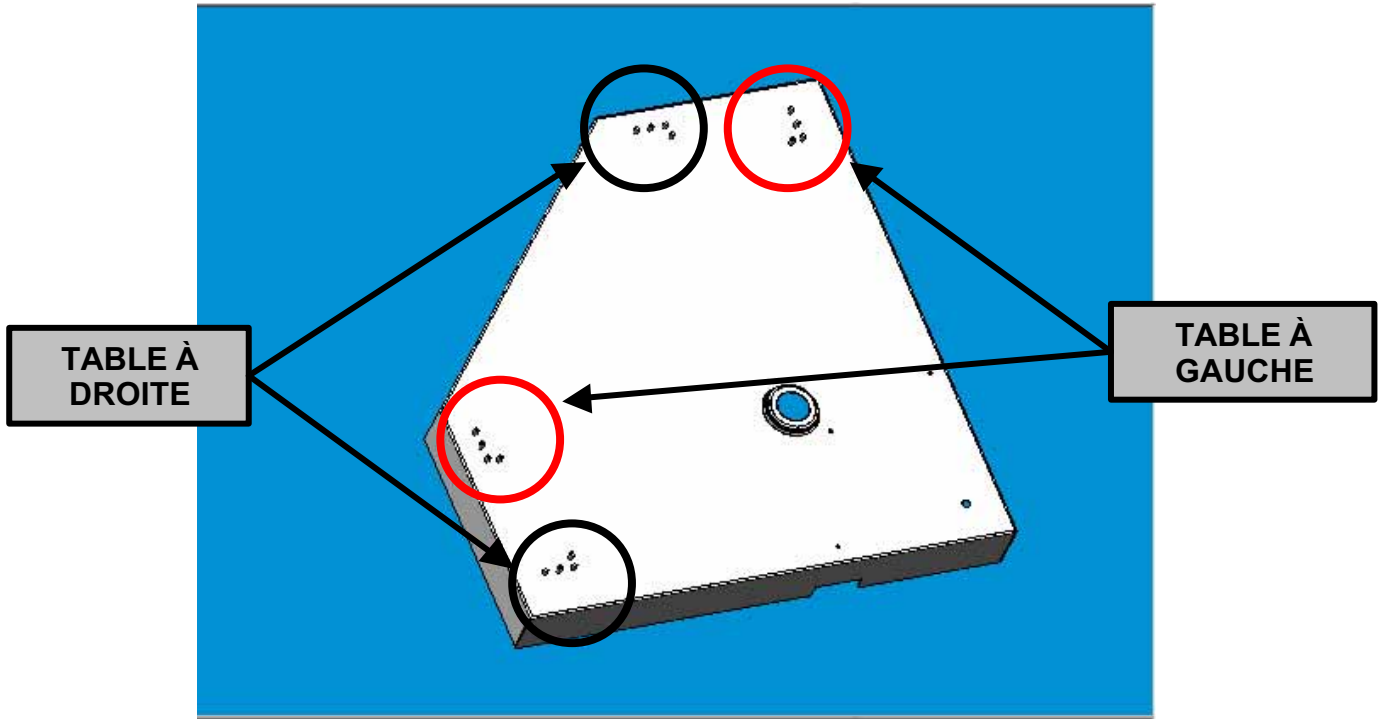

CÔTÉ SUPÉRIEUR DE LA GRILLE

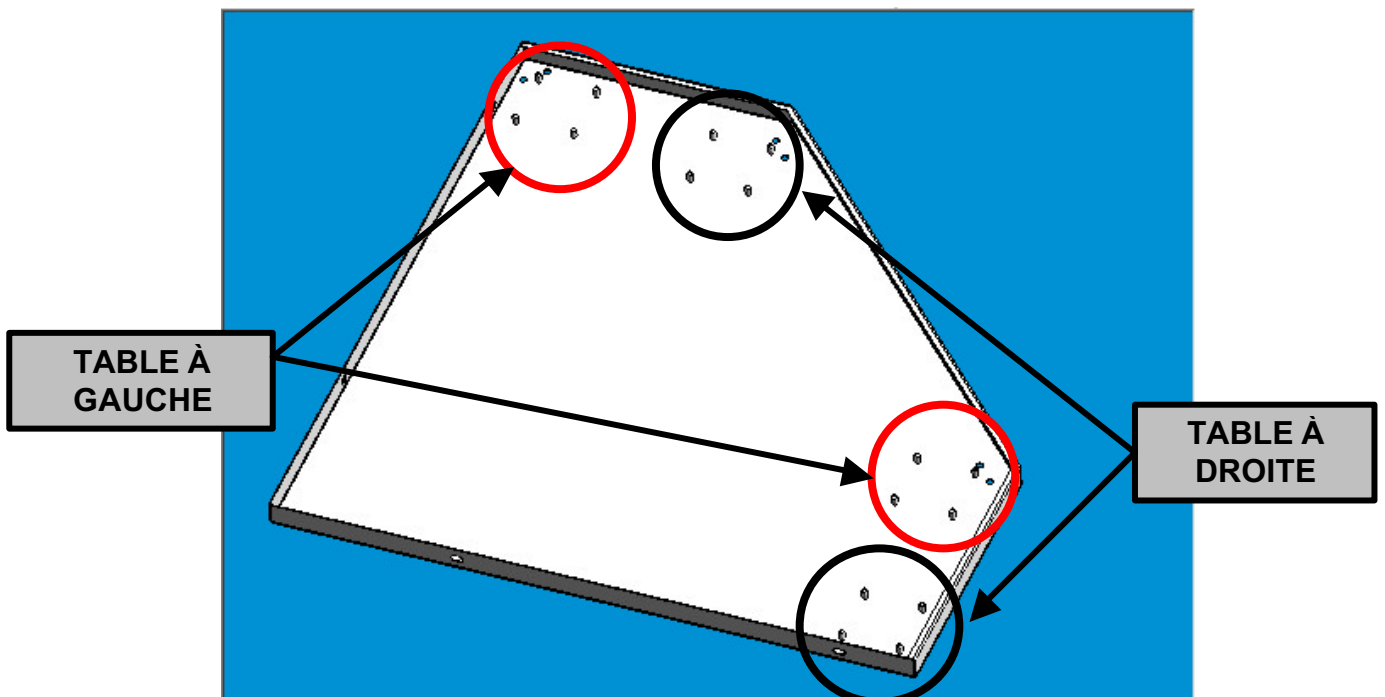

**POSITIONNEMENT DES BOULONS DE LA JONCTION DES
PIEDS AVEC LA TABLE DU LAVE-VAISSELLE À 90°**

SANS Tunnel de séchage

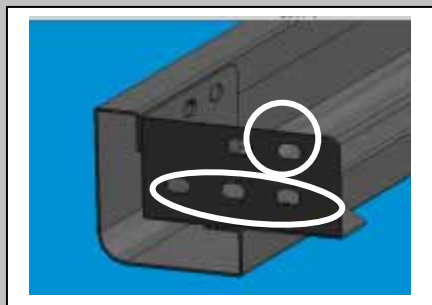
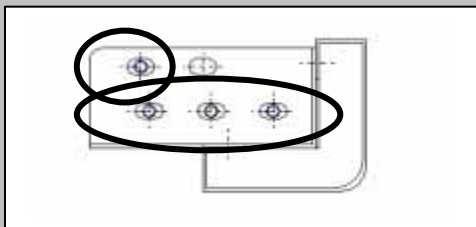

AVEC Tunnel de séchage

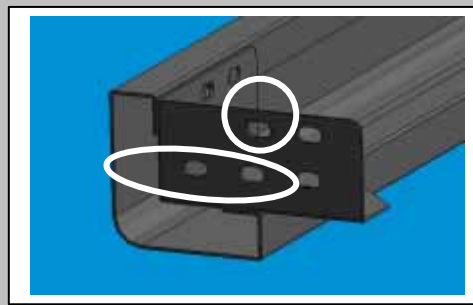
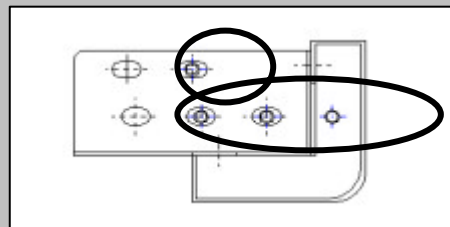

LISTE DES PIÈCES INCLUSES DANS LE KIT D'INSTALLATION DE LA TABLE À 90°

REF.	DÉNOMINATION	DROITE T.S. 1210309007	DROITE 1210309009	GAUCHE T.S. 1210309008	GAUCHE 1210309010
Z312500000	TABLE 90° DROITE COMPLÈTE	1	1	-	-
Z312504000	PIED TABLE 90° COMPLÈTE	2	2	2	2
Z312519000	FIXATION PIED TABLE 90°	2	2	2	2
Z312520000	RACCORD DROIT 90° COMPLET	1	1	-	-
Z702101000	ÉCROU F.1 1/2 DERLIN	1	1	1	1
Z312506000	GRILLE COMPLÈTE 90° DROITE	1	-	-	-
Z312529000	GRILLE COMPL. T E/S 90° DROITE	-	1	-	-
X260151000	PIED RÉGLABLE	2	2	2	2
Z312528000	JONCTION TABLE-LAVE-V. DROITE	1	1	-	-
Z312539000	BARRE DE POUSSÉE 90°	1	1	-	-
Z272583000	SUPPLÉMENT DROIT TABLE 180°	1	1	-	-
Z312517000	INSTALLATION TABLE 90°	1	1	1	1
Z312503000	TABLE 90° GAUCHE COMPLÈTE	-	-	1	1
Z312526000	RACCORD GAUCHE 90° COMPLET	-	-	1	1
Z312507000	GRILLE COMPLÈTE 90° GAUCHE	-	-	1	-
Z312531000	GRILLE COMPL. T E/S 90° GAUCHE	-	-	-	1
Z312534000	JONCTION TABLE-LAVE-V. GAUCHE	-	-	1	1
Q032041000	VIS T. BOMB. M6X10	5	5	5	5
Q232040000	RONDELLE A6	7	7	7	7
Q262040000	ROND. GROW. A6 A 304	7	7	7	7
Q212040000	ÉCROU CHAP. M6	5	5	5	5
Q242030000	ROND. ÉVENT. A5 A 304	8	8	8	8
Q012031000	VIS HEXA. M5X10 A304	8	8	8	8
Q232050000	RONDELLE A8	4	4	4	4
0120430000	VIS HEXA. M6X20 A 304	4	4	4	4
Q262040000	ROND. GROW. A6 A 304	4	4	4	4
Q212040000	ÉCROU CHAP. M6	4	4	4	4

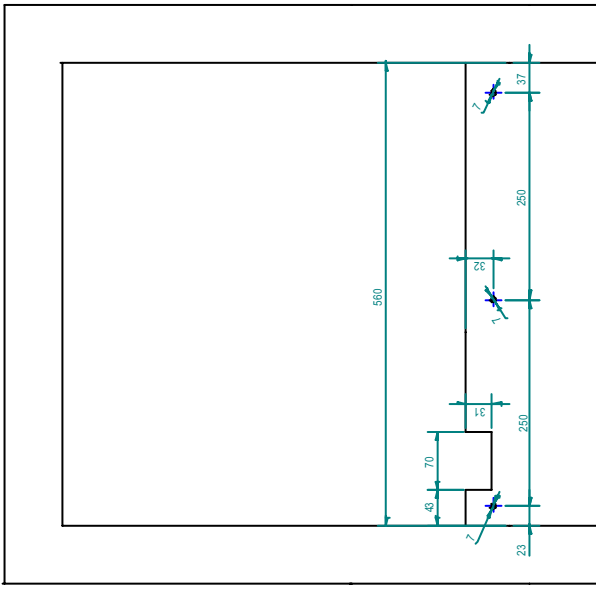

Exit of raised appliance (left version)

Front of
appliance

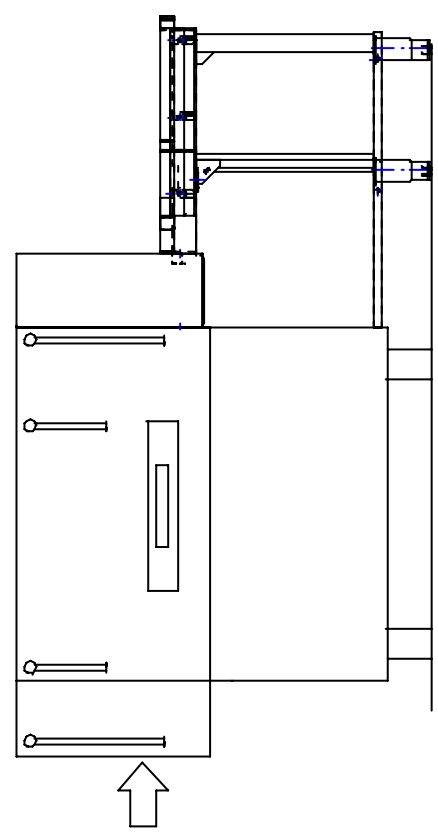

Right table: Right attachment table-dishwasher (Z-312528)
Left: Left attachment table-dishwasher (Z-312534)

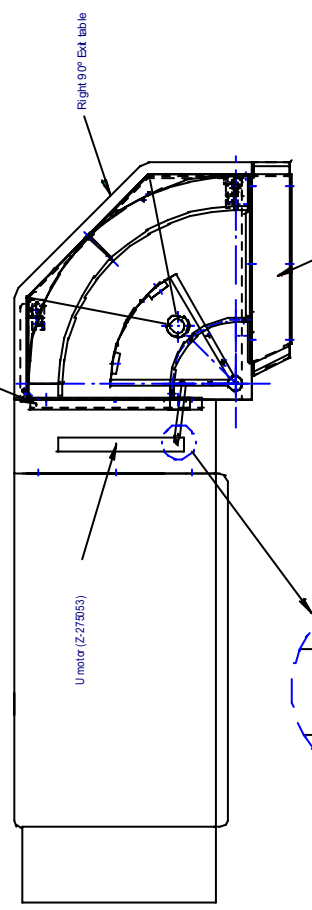

Right table: Complete right connector (Z-312520)
Left table: Complete left connector (Z-312526)

- 90° table anchoring to dishwasher and to connector:
- Hexag. Screw: M6x10
 - Washer: A6
 - Grease Washer: A6
 - Bonne/nut: M6

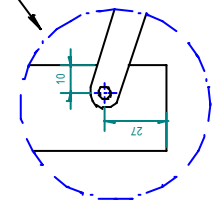

Thrust bar anchoring to dishwasher details
(Make a hole Ø6)

INSTRUCTIONS FOR THE ASSEMBLY OF THE 90° EXIT TABLE

LOWER SIDE OF TABLE

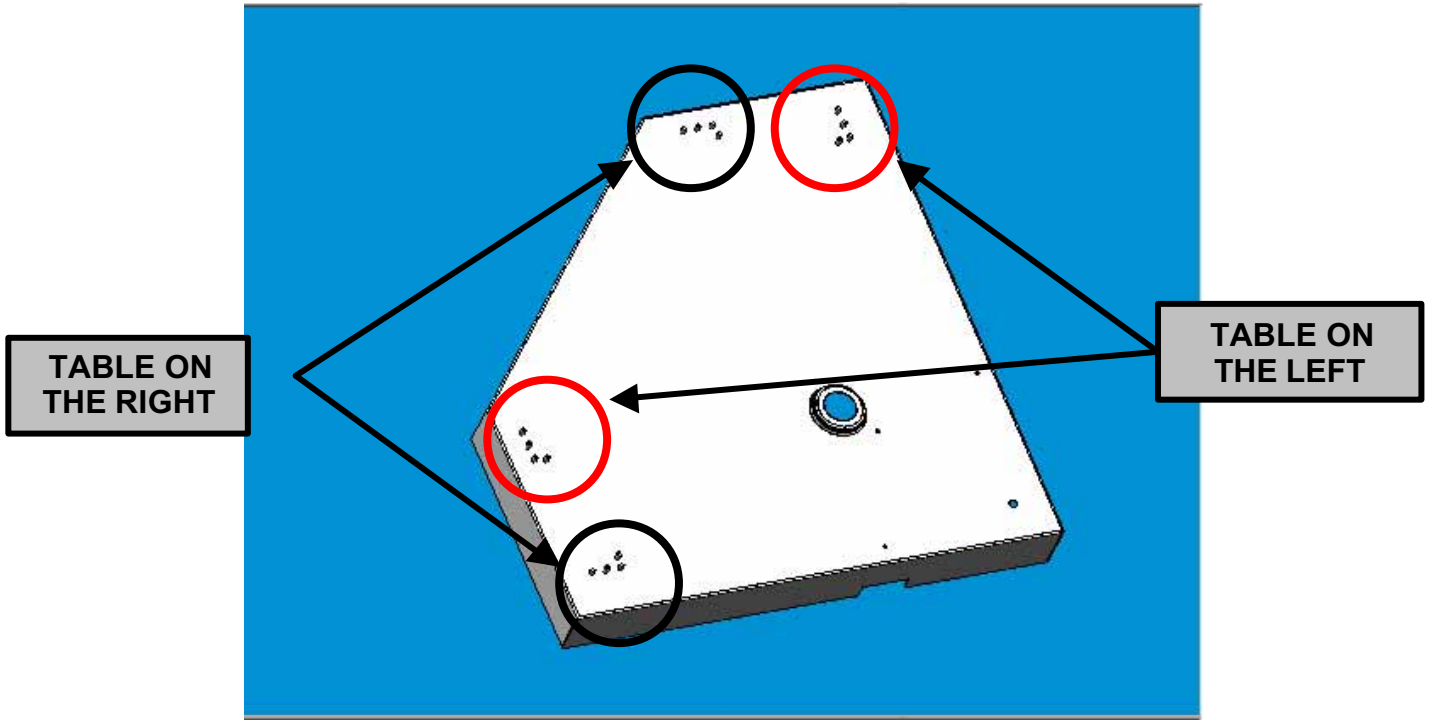

UPPER SIDE OF THE TRAY

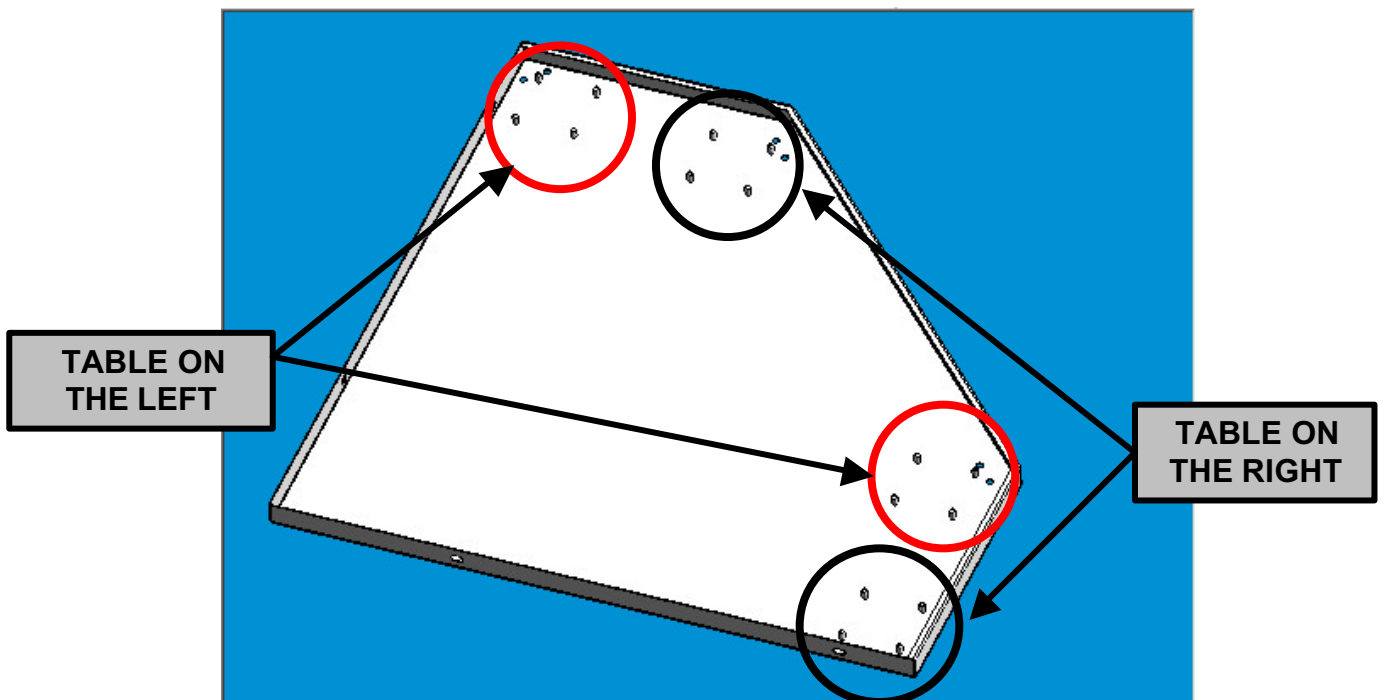

**POSITIONING OF BOLTS FOR LEG ASSEMBLY TO THE 90°
DISHWASHER TABLE'S LEGS**

WITHOUT DRYING TUNNEL

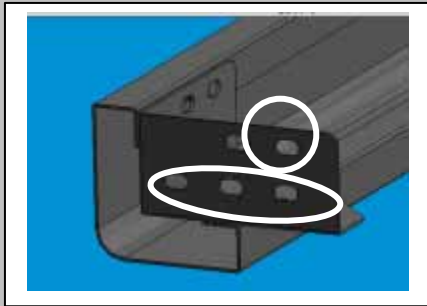
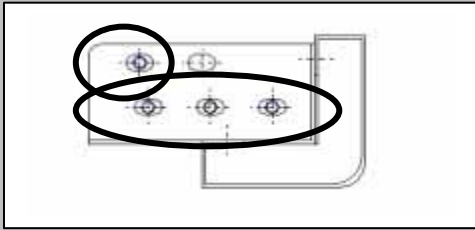

WITH DRYING TUNNEL

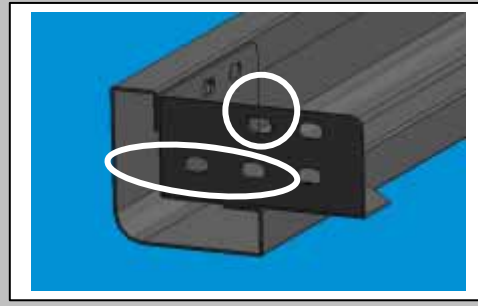
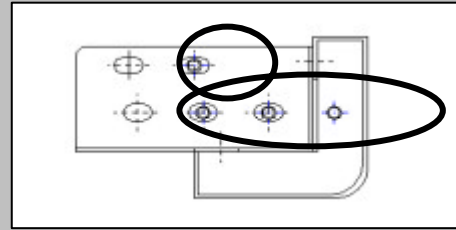

LIST OF PARTS INCLUDED IN 90° TABLE INSTALLATION KIT

REF.	DENOMINATION	RIGHT D.T. 1210309007	RIGHT TRAY 1210309009	LEFT D.T. 1210309008	LEFT 1210309010
Z312500000	COMPLETE RIGHT 90° TABLE	1	1	-	-
Z312504000	COMPLETE 90° TABLE LEG	2	2	2	2
Z312519000	90° TABLE LEG ANCHORING	2	2	2	2
Z312520000	COMPLETE 90° RIGHT CONNECTOR	1	1	-	-
Z702101000	1 THREAD 1/2 DERLIN NUT	1	1	1	1
Z312506000	COMPLETE 90° RIGHT TRAY	1	-	-	-
Z312529000	90° ENTRY/EXIT TUNNEL COMPLETE TRAY	-	1	-	-
X260151000	ADJUSTABLE LEG	2	2	2	2
Z312528000	RIGHT TABLE-DISHWASHER CONNECTOR	1	1	-	-
Z312539000	90° THRUST BAR	1	1	-	-
Z272583000	180° TABLE RIGHT SUPPLEMENT	1	1	-	-
Z312517000	90° TABLE INSTALLATION	1	1	1	1
Z312503000	COMPLETE 90° LEFT TABLE	-	-	1	1
Z312526000	COMPLETE 90° RIGHT CONNECTOR	-	-	1	1
Z312507000	90° LEFT COMPLETE TRAY	-	-	1	-
Z312531000	90° LEFT ENTRY/EXIT TUNNEL COMPLETE TRAY	-	-	-	1
Z312534000	LEFT TABLE-DISHWASHER CONNECTOR	-	-	1	1
Q032041000	CURVE BACKED SCREW M6X10	5	5	5	5
Q232040000	WASHER A6	7	7	7	7
Q262040000	GROWER WASHER A6 A 304	7	7	7	7
Q212040000	BONNET NUT M6	5	5	5	5
Q242030000	FAN-TYPE WASHER A5 A 304	8	8	8	8
Q012031000	HEX. SCREW M5X10 A304	8	8	8	8
Q232050000	WASHER A8	4	4	4	4
0120430000	HEX. SCREW M6X20 A 304	4	4	4	4
Q262040000	GROWER WASHER A6 A 304	4	4	4	4
Q212040000	BONNET NUT M6	4	4	4	4

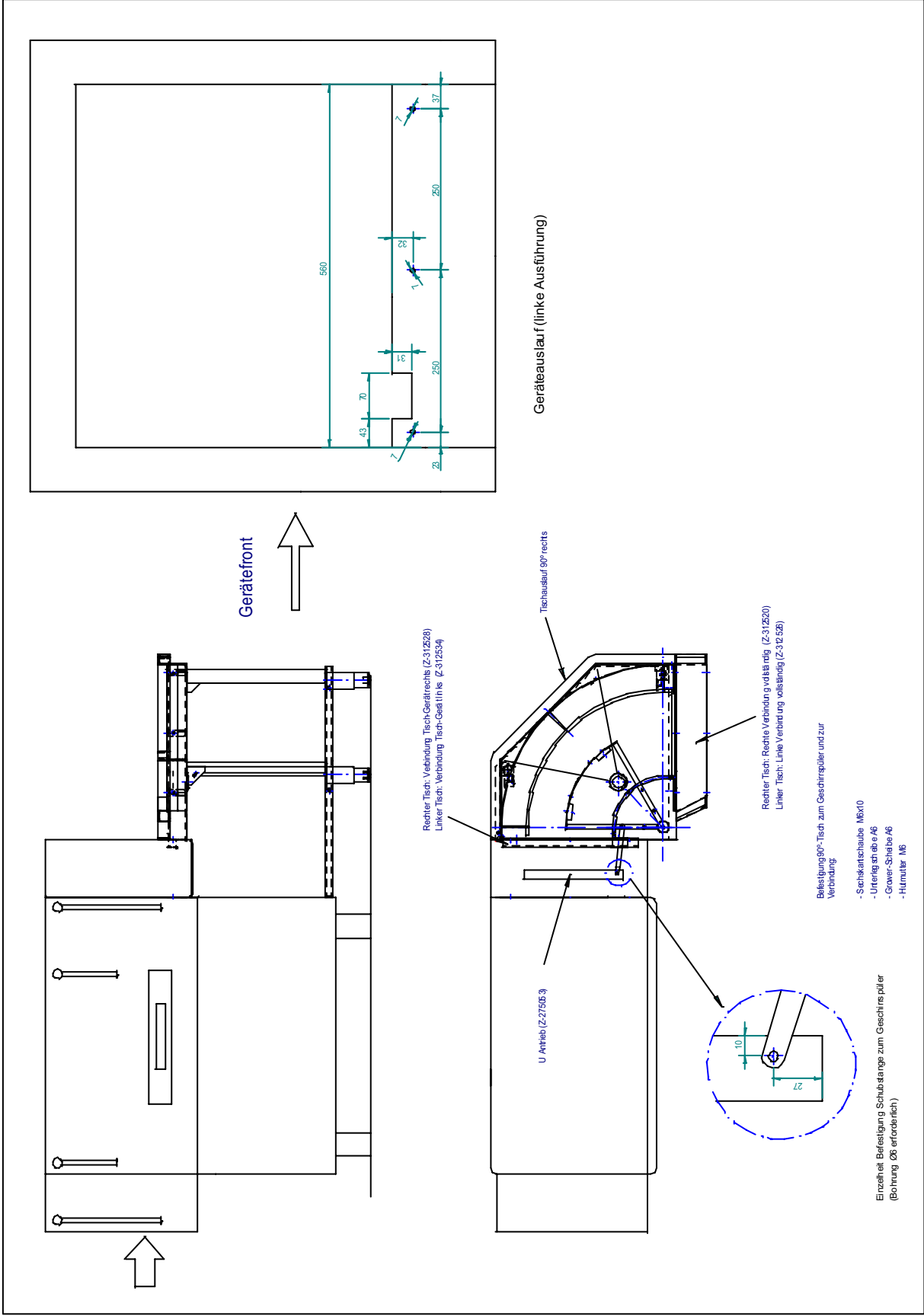

ANWEISUNGEN ZUM EINBAU DES 90°-TISCHES

UNTERE TISCHSEITE

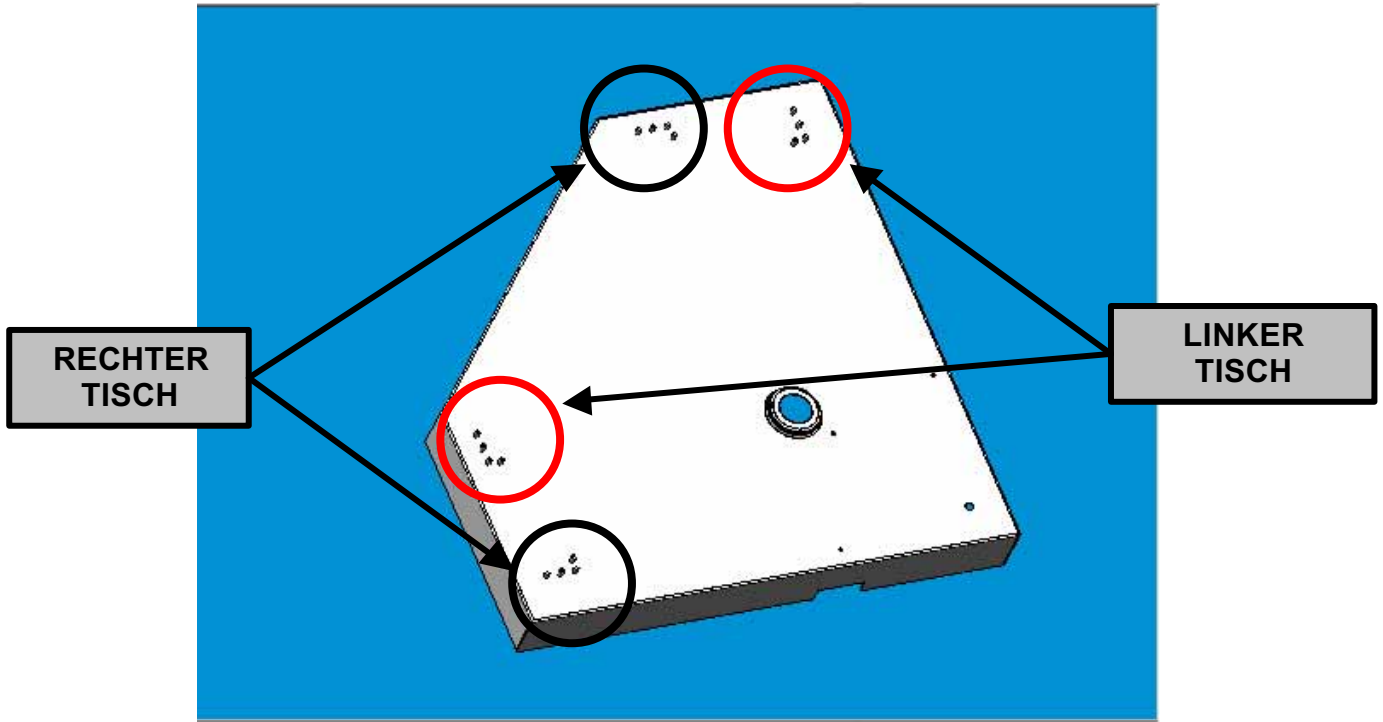

OBERSEITE DES EINSCHUBS

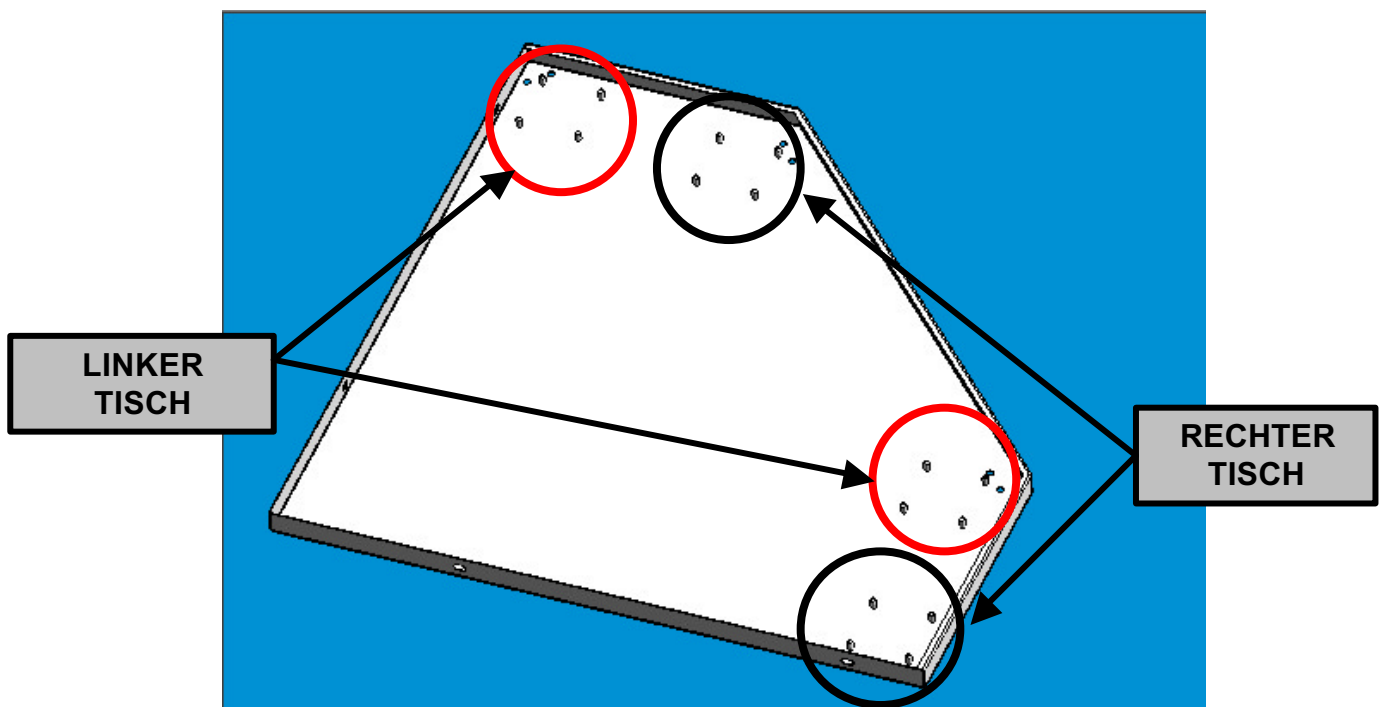

**POSITIONIERUNG DER VERBINDUNGSBOLZEN FÜR DIE
BEINE AM TISCH DES GESCHIRRSPÜLERS BEI 90°**

OHNE TROCKENTUNNEL

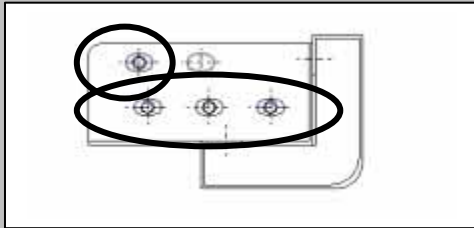

MIT TROCKENTUNNEL

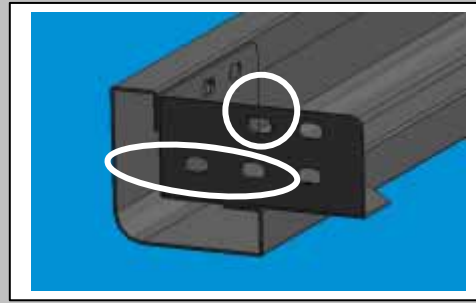
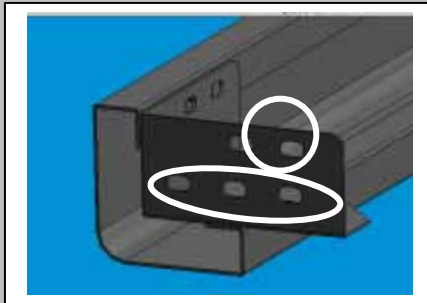
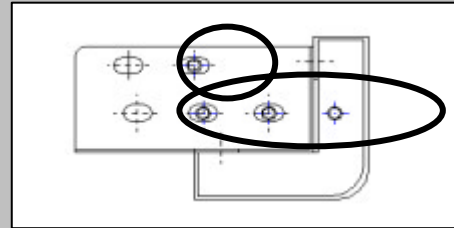

IM INSTALLATIONSPACK FÜR DEN 90°-TISCH ENTHALTENE TEILE

NR.	BENENNUNG	RECHTS T.S. 1210309007	RECHTS 1210309009	LINKS T.S. 1210309008	LINKS 1210309010
Z312500000	90°-TISCH, RECHTE AUSFÜHRUNG	1	1	-	-
Z312504000	BEIN 90°-TISCH, KOMPLETT	2	2	2	2
Z312519000	BEFESTIGUNG BEIN 90°-TISCH	2	2	2	2
Z312520000	VERBINDUNGSELEMENT RECHTS 90° KOMPLETT	1	1	-	-
Z702101000	MUTTER 11/2 DERLIN	1	1	1	1
Z312506000	EINSCHUB KOMPLETT 90° RECHTS	1	-	-	-
Z312529000	EINSCHUB KOMPLETT T E/S 90° RECHTS	-	1	-	-
X260151000	HÖHENVERSTELLBARER FUSS	2	2	2	2
Z312528000	VERBINDUNG TISCH-GESCHIRRSPÜLER RECHTS	1	1	-	-
Z312539000	ANTRIEBSSTANGE 90°	1	1	-	-
Z272583000	ERWEITERUNG RECHTS 180°-TISCH	1	1	-	-
Z312517000	INSTALLATION 90°-TISCH	1	1	1	1
Z312503000	90°-TISCH LINKS KOMPLETT	-	-	1	1
Z312526000	VERBINDUNGSELEMENT LINKS 90° KOMPLETT	-	-	1	1
Z312507000	EINSCHUB KOMPLETT 90° LINKS	-	-	1	-
Z312531000	EINSCHUB KOMPLETT T E/S 90° LINKS	-	-	-	1
Z312534000	VERBINDUNG TISCH-GESCHIRRSPÜLER LINKS	-	-	1	1
Q032041000	SENKKOPFSCHRAUBE M6X10	5	5	5	5
Q232040000	UNTERLEGSCHEIBE A6	7	7	7	7
Q262040000	GROWERSCHEIBE A6 A 304	7	7	7	7
Q212040000	HUTMUTTER M6	5	5	5	5
Q242030000	FEDERSCHEIBE A5 A 304	8	8	8	8
Q012031000	SECHSKANTSCHRAUBE M5X10 A304	8	8	8	8
Q232050000	UNTERLEGSCHEIBE A8	4	4	4	4
0120430000	SECHSKANTSCHRAUBE M6X20 A 304	4	4	4	4
Q262040000	GROWERSCHEIBE A6 A 304	4	4	4	4
Q212040000	HUTMUTTER M6	4	4	4	4

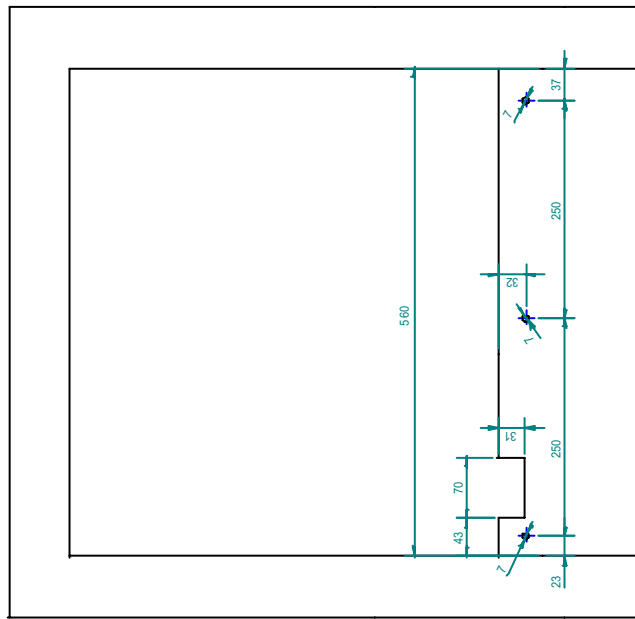
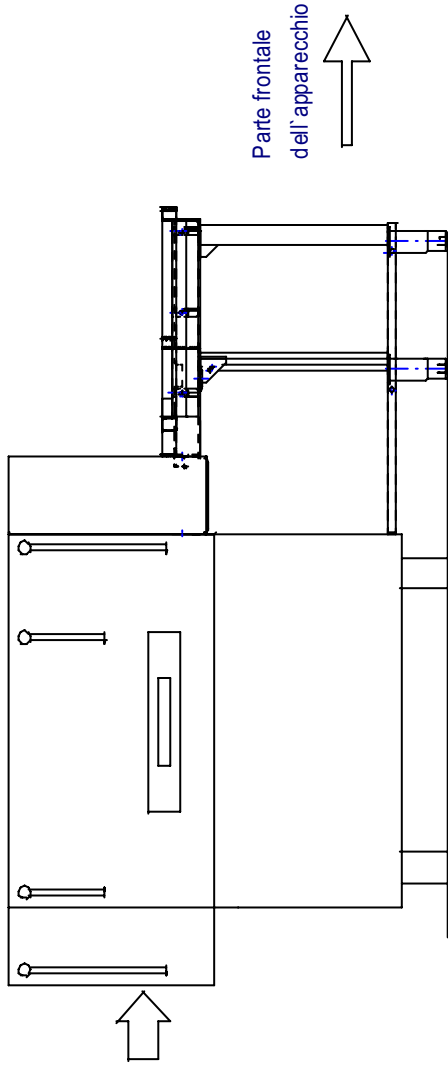

Uscita dell'apparecchio e vista (versione sinistra)

Tavolo destro: Unione tavolo-lav. destro (Z-312528)
 Tavolo sinistro: Unione tavolo-lav. sinistro (Z-312534)

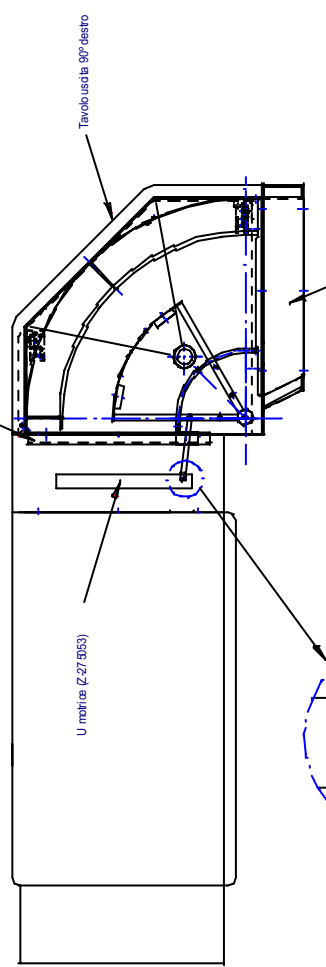

Tavolo destro: Unione destra completa (Z-312520)
 Tavolo sinistro: Unione sinistra completa (Z-312526)

Attacco tavolo 90° al Lavastoviglie e all'Unione:

- Vite esagonale M8x10
- Rondella A6
- Rondella CoverA6
- Dado testa di camino M6

Dettaglio attacco Barra di Spinta al lavastoviglie (Perforare Ø6)

ISTRUZIONI PER MONTAGGIO DEL TAVOLO A 90°

LATO INFERIORE DEL TAVOLO

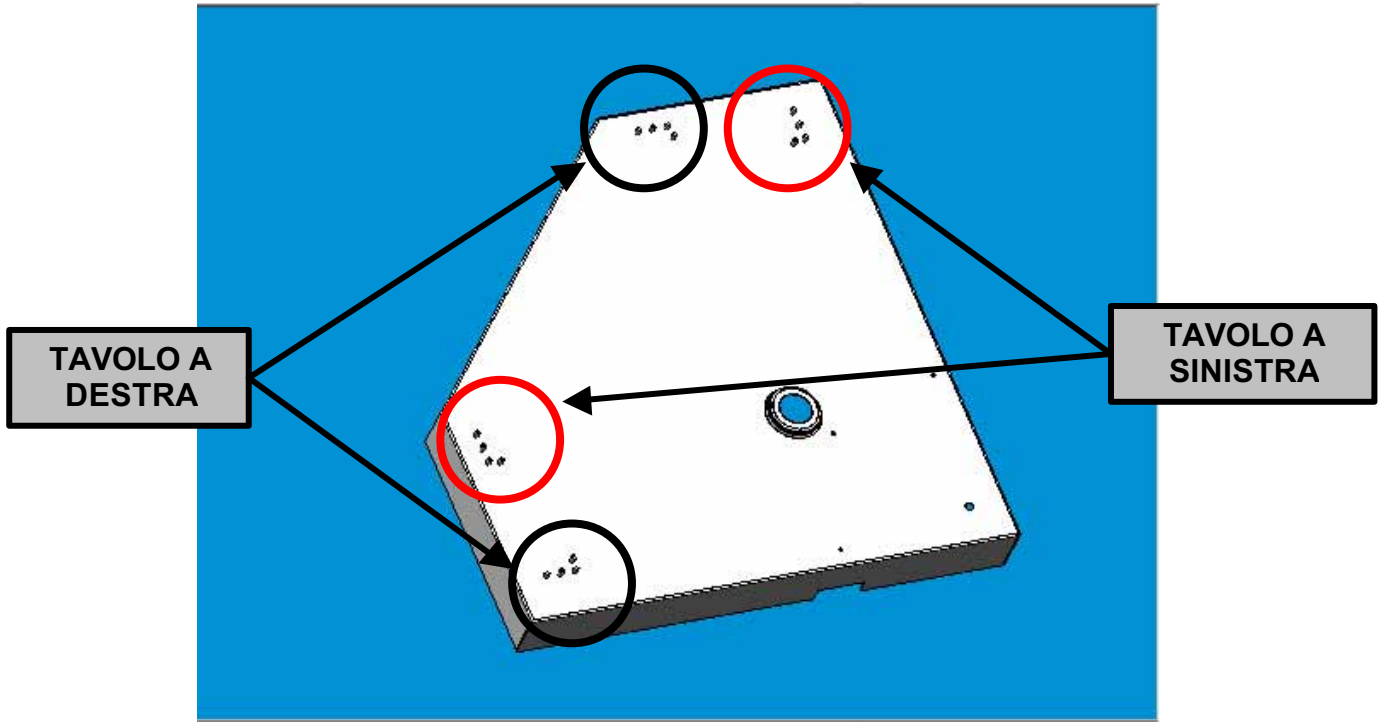

LATO SUPERIORE DEL RIPIANO

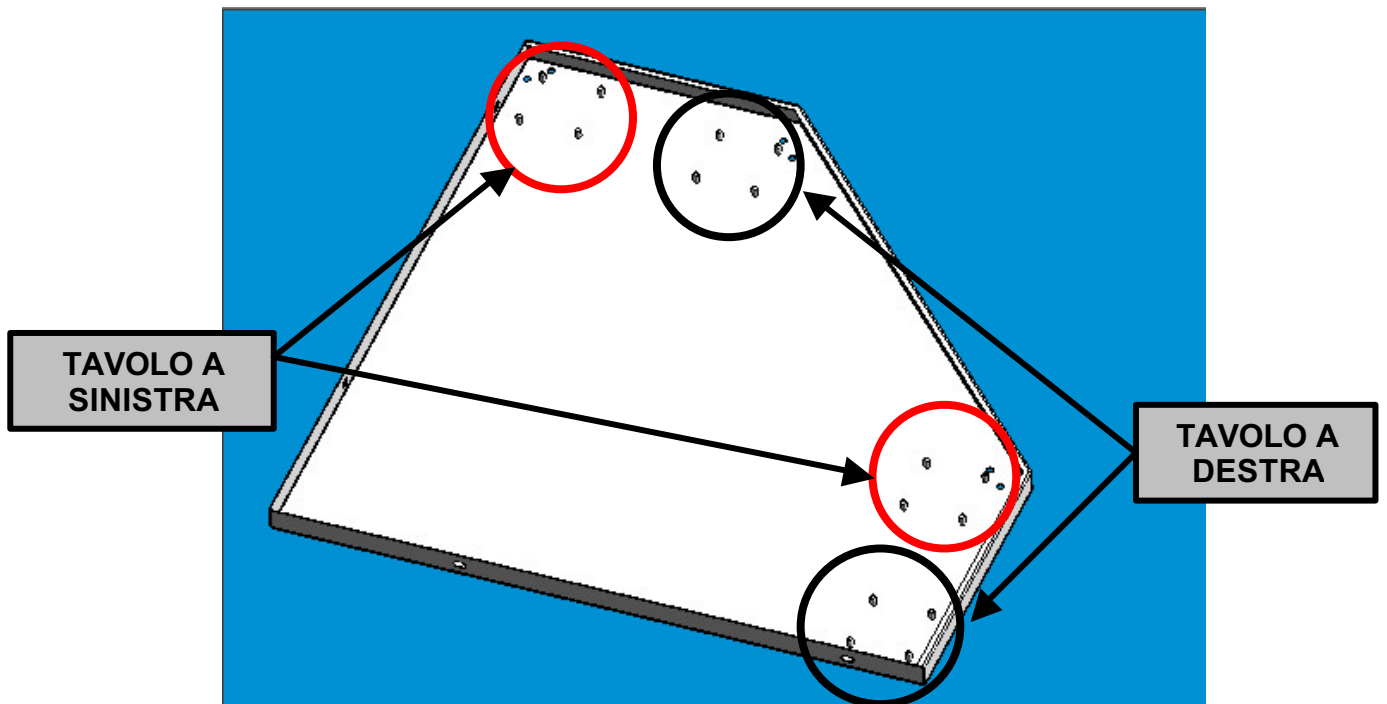

POSIZIONAMENTO DEI PERNI D'UNIONE DEI PIEDI CON IL TAVOLO DEL LAVASTOVIGLIE A 90°

SENZA TUNNEL DI ASCIUGATURA

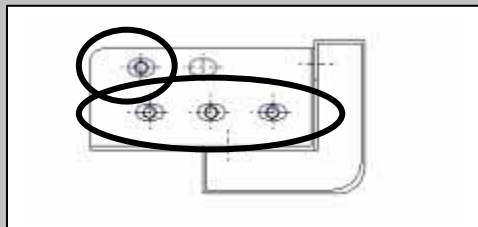

CON TUNNEL DI ASCIUGATURA

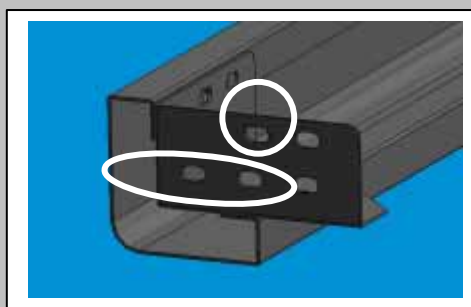
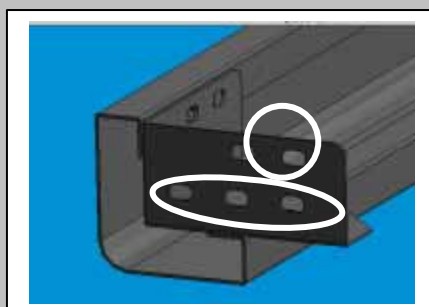
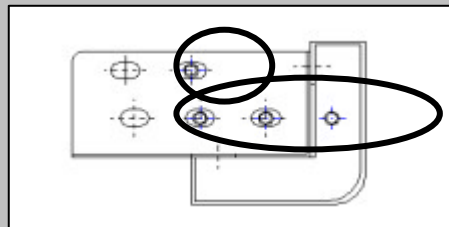

ELENCO PEZZI INCLUSI NEL KIT DI INSTALLAZIONE DEL TAVOLO A 90°

RIF.	DENOMINAZIONE	DESTRO T.A. 1210309007	DESTRO 1210309009	SINISTRO T.A. 1210309008	SINISTRO 1210309010
Z312500000	TAVOLO 90° DESTRO COMPLETO	1	1	-	-
Z312504000	PIEDE TAVOLO 90° COMPLETO	2	2	2	2
Z312519000	ATTACCO PIEDE TAVOLO 90°	2	2	2	2
Z312520000	ATTACCO DESTRO 90° COMPLETO	1	1	-	-
Z702101000	DADO F.11/2 DERLIN	1	1	1	1
Z312506000	RIPIANO COMPLETO 90° DESTRO	1	-	-	-
Z312529000	RIPIANO COMPL. T E/U 90° DESTRO	-	2	2	2
X260151000	PIEDE REGOLABILE	2	1	-	-
Z312528000	UNIONE TAVOLO- LAVAST. DESTRA	1	1	-	-
Z312539000	BARRA SPINTA 90°	1	1	-	-
Z272583000	SUPPLEMENTO DESTRO TAVOLO180°	1	1	-	-
Z312517000	INSTALLAZIONE TAVOLO 90°	1	1	1	1
Z312503000	TAVOLO 90° SINISTRO COMPLETO	-	-	1	1
Z312526000	UNIONE SINISTRA 90° COMPLETA	-	-	1	1
Z312507000	RIPIANO COMPLETO 90° SINISTRO	-	-	1	-
Z312531000	RIPIANO COMPL. T E/U 90° SINISTRO	-	-	-	1
Z312534000	UNIONE TAVOLO- LAVAST. SINISTRO	-	-	1	1
Q032041000	VITE BOMBATA M6X10	5	5	5	5
Q232040000	RONDELLA A6	7	7	7	7
Q262040000	RONDELLA GROW. A6 A 304	7	7	7	7
Q212040000	DADO TESTA DI CAM. M6	5	5	5	5
Q242030000	ROND. VENT. A5 A 304	8	8	8	8
Q012031000	VITE. ESAG. M5X10 A304	8	8	8	8
Q232050000	RONDELLA A8	4	4	4	4
0120430000	VITE. ESAG. M6X20 A 304	4	4	4	4
Q262040000	RONDELLA GROW. A6 A 304	4	4	4	4
Q212040000	DADO TESTA DI CAM. M6	4	4	4	4