

**AUTOMATIC ICE - CUBE MAKER**

**INSTALLATION,  
USE AND MAINTENANCE  
MANUAL**

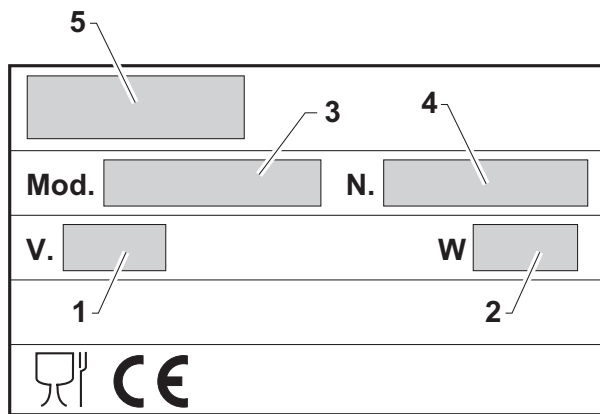
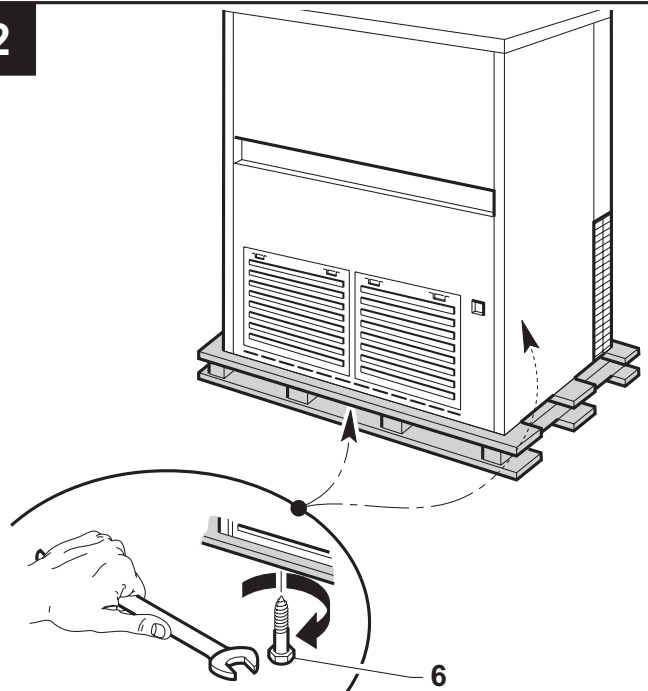
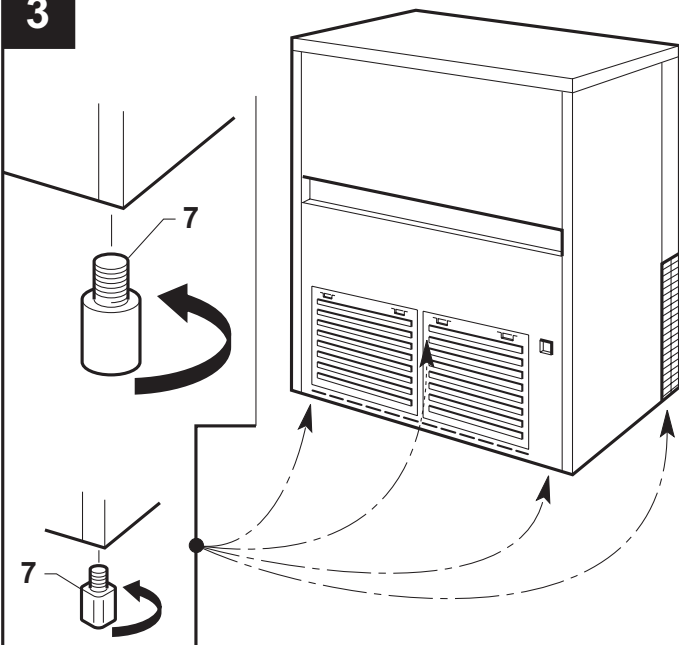
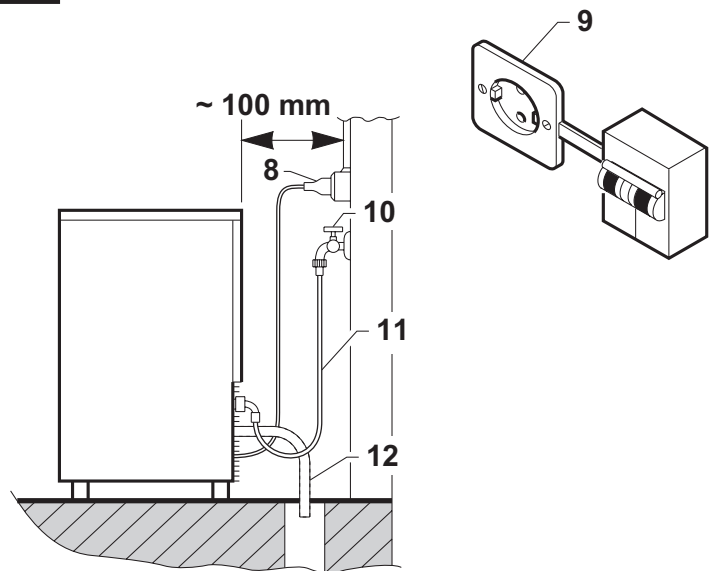
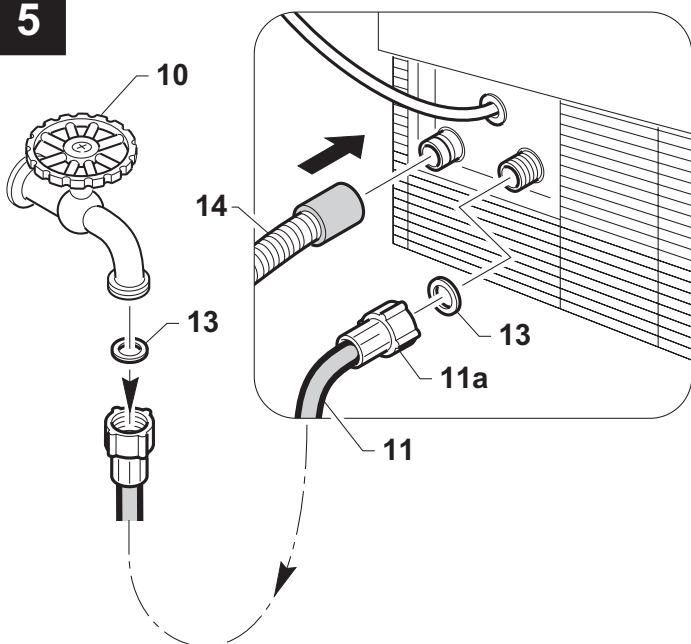
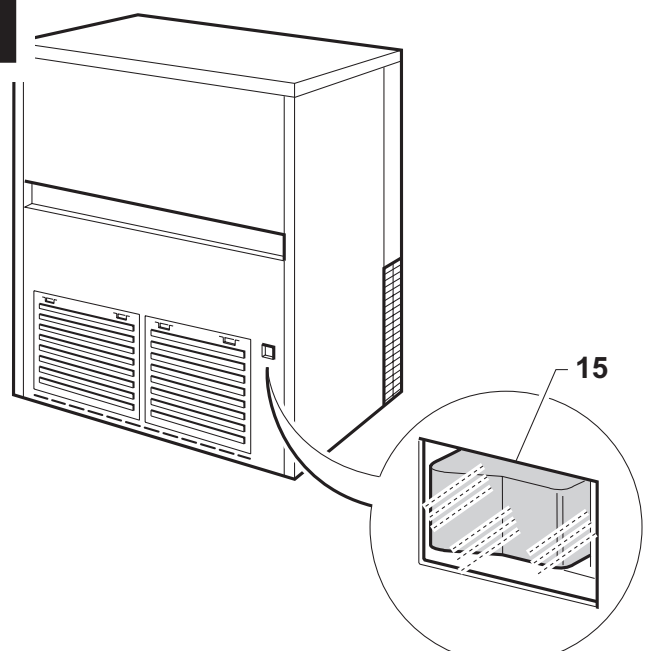

**1****2****3****4****5****6**

7

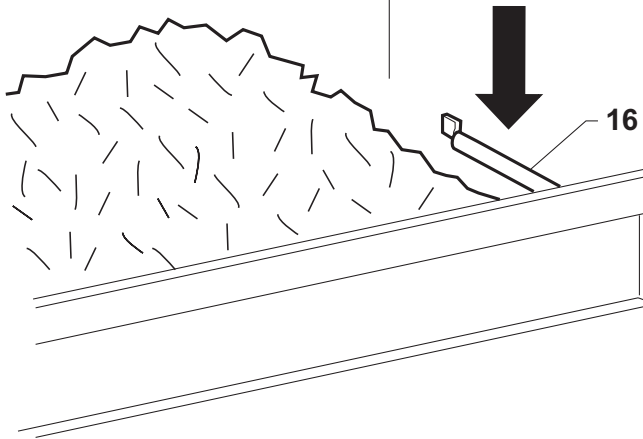

8

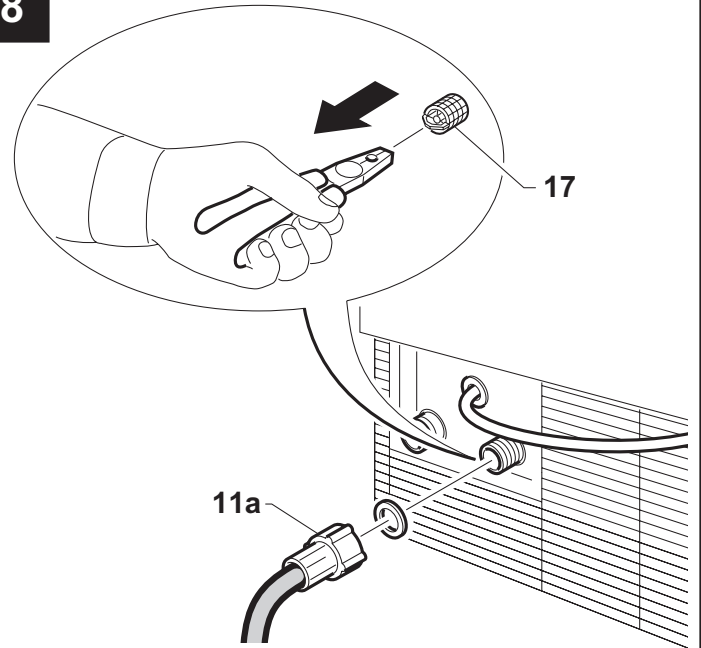

9

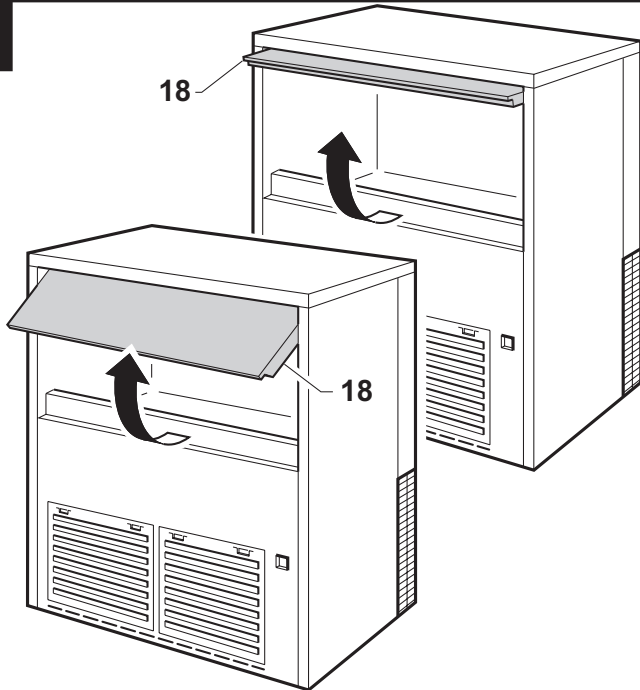

Dear Customer,

Congratulations on having chosen a quality product which will certainly fully meet your expectations. Thank you for having purchased one of our products. Please read this Instruction Manual carefully before using your new automatic granular flaked-ice maker.

## INDEX

<b>1</b>	<b>IMPORTANT ADVICE AND RECOMMENDATIONS .....</b>	<b>Page 6</b>
<b>2</b>	<b>TECHNICAL SPECIFICATIONS .....</b>	<b>Page 7</b>
<b>3</b>	<b>ADVICE ABOUT TRANSPORTATION .....</b>	<b>Page 7</b>
<b>4</b>	<b>UNPACKING .....</b>	<b>Page 7</b>
<b>5</b>	<b>INSTALLATION .....</b>	<b>Page 7</b>
	5.1 CONNECTION DIAGRAM .....	Page 7
	5.2 POSITIONING .....	Page 8
	5.3 CONNECTION TO THE ELECTRICITY MAIN .....	Page 8
	5.4 CONNECTION TO WATER MAINS .....	Page 8
	5.4.a WATER SUPPLY .....	Page 9
	5.4.b DRAINAGE .....	Page 9
<b>6</b>	<b>START-UP .....</b>	<b>Page 9</b>
	6.1 CLEANING INTERNAL PARTS .....	Page 9
	6.2 START-UP .....	Page 9
<b>7</b>	<b>MAIN CAUSES OF OPERATING FAILURE .....</b>	<b>Page 9</b>
<b>8</b>	<b>OPERATION .....</b>	<b>Page 10</b>
<b>9</b>	<b>MAINTENANCE .....</b>	<b>Page 10</b>
	9.1 CLEANING THE SOLENOID VALVE FILTER .....	Page 10
	9.2 AIR-COOLED MODELS .....	Page 10
	9.3 CLEANING AND SANITIZING THE ICE-TRAY .....	Page 10
<b>10</b>	<b>PERIODS AT A STANDSTILL .....</b>	<b>Page 11</b>

*The figures in this Manual are of a general nature. Some details may therefore differ depending on the specific model.*

## 1 IMPORTANT ADVICE AND RECOMMENDATIONS

This instruction manual forms an integral part of the automatic granular flaked-ice maker (also more simply called “appliance” in the text) and must be kept for possible future consultation.

In the event of the appliance being sold or transferred to another person, this Manual must be handed over to the new user, in order to enable him to become familiar with the operation of the equipment and the corresponding advice and recommendations.

 **Before installing and using the appliance, read the advice and recommendations contained in this Instruction Manual very carefully. They are given in order to ensure safe installation, use and maintenance of the appliance.**

Any specific information or diagrams regarding particular models will be attached to this Instruction Manual.

 **Do not remove any of the panels or grilles.**

 **Open and close the door carefully without slamming it.**

 **Do not rest objects on the appliance or in front of the ventilation grilles.**

 **Always lift the appliance to move it. Do not push or pull it.**

 **Always remove the plug from the power socket before proceeding with any cleaning or maintenance operations.**

Any use of the appliance other than for the production of granular flaked ice from cold drinking water, is to be considered as improper use.

Do not use the flaked-ice container to cool or preserve food or drinks, as these operations could cause the drainage system to become clogged, thus leading to the container filling up and water leaking out.

 **Do not obstruct the ventilation and heat-dissipation grilles, since poor aeration – in addition to reducing efficiency and causing poor operation – may also cause serious damage to the appliance.**

**Read the following warnings carefully:**

Use of this electrical appliance, requires compliance with certain fundamental rules; in particular:

- Do not touch the appliance with wet or damp hands or feet.
- Do not use the appliance when you are barefoot.
- Do not use extensions in premises such as bathrooms or shower rooms.
- Do not tug on the power supply cable to disconnect it from the mains supply.
- Do not allow the appliance to be used by children or by incapable persons.

 **If the appliance breaks down and/or operates in a faulty way, switch it off by means of the main switch fitted during the installation phase, turn off the water tap, and do not make any attempt to repair the appliance yourself. Contact only professionally qualified and authorized personnel.**

In addition to rendering any form of warranty null and void, modifying (or attempting to modify) this appliance is extremely dangerous.

 **To ensure the appliance operates efficiently and correctly, it is essential to comply with the manufacturer’s instructions and to make sure that maintenance is performed by specially qualified personnel.**

In the event of a failure, contact the dealer who sold you the appliance; he will be able to give you the address of your nearest Authorized Technical Service Center. Always insist on having genuine spare parts mounted.



Should you decide to scrap the appliance, first disconnect the power supply cable from the mains, and then cut the cable off.

In addition, proceed as follows:

- Break off and remove the door in order to prevent the possible danger of a child getting trapped inside.
- Do not allow the coolant gas and oil in the compressor to disperse into the environment.
- Dispose of or recover the various materials according to the provisions established by the current laws in force in your country.

**This appliance does not contain coolant that damages the ozone layer.**



**The manufacturer shall not be liable for any damage to the environment, animals, persons or objects caused by incorrect installation.**

## 2 TECHNICAL DATA (Fig. 1)

The voltage and frequency are given on the data plate on the appliance. Refer to this data plate to check compliance.

Voltage (1), power (2), model (3), Serial No. (4) manufacturer (5).

The weighted equivalent continuous sound level A of this appliance is less than 70 dB (A). The measurements were over an entire production cycle, at a distance of 1 m from the surface of the appliance and at a height of 1.60 m from the floor.

The wiring diagram is stuck on the front counterpanel of the appliance.

In order to gain access thereto, unplug the appliance from the power source, unscrew the screws holding the front panel, and slide it away after first opening the door.

## 3 ADVICE ABOUT TRANSPORTATION

The net weight and the weight including packaging of the appliance are given on the cover of this Instruction Manual. Please refer to the instructions on the packaging in order to correctly transport and lift the appliance.

To prevent the oil in the compressor from flowing back into the coolant circuit, always make sure that the appliance is kept upright during transport, storage, and handling. Follow the instructions given on the packaging.

## 4 UNPACKING

**The appliance must be installed by authorized personnel in compliance with the current laws in force and the manufacturer's instructions.**

Once you have removed the packaging according to the instructions on the box, make sure that THE APPLIANCE IS IN A PERFECTLY GOOD CONDITION. If in doubt, DO NOT USE IT and immediately CONTACT the dealer who sold it to you.

All the packaging items (plastic bags, cardboard, polystyrene foam, nails, etc.) must be removed and put out of the reach of children, as they are potential sources of danger.

Rest the wooden pallet on the floor and, using a hex socket wrench, loosen and remove the bolts (6 Fig. 2) that fix the appliance to the pallet.

Lift the appliance using equipment fit to bear its weight. Separate the appliance from the wooden pallet and fit the supplied feet into the housings on the base plate provided for the purpose. (7 Fig. 3).

Use a spirit level to ensure that the appliance is standing perfectly level. If necessary, adjust the feet.

## 5 INSTALLATION

### 5.1 CONNECTION DIAGRAM (see Fig. 4)

8. Plug
9. Socket with switch
10. Water tap
11. Water supply pipe
12. Water drainage pipe

## **5.2 POSITIONING**

It is advisable to install the appliance in a room where the temperature is between 10°C and 35°C, and with a water supply temperature of between 3°C and 25°C.

Avoid installing the appliance where it may be exposed to direct sunlight or near heat sources such as radiators, stoves, dishwashers, etc.



This appliance

- must not be used outdoors
- must not be installed in damp places or where it is liable to be sprayed with water

## **5.3 CONNECTION TO THE ELECTRICITY MAIN**



Before connecting the appliance to the electricity main, make sure that the mains voltage rating corresponds to the value indicated on the rating plate.



Make sure that the appliance is connected to an efficient earthing system.



Make sure that the capacity of the power supply system suits the maximum power value indicated on the rating plate of the appliance.



To ensure that the appliance is correctly and safely installed, provide an adequate socket controlled by an omnipolar circuit-breaker (9 Fig. 4), with a contact opening gap of not less than 3 mm, in accordance with current national safety standards. This switch must be equipped with fuses, with the associated residual current device positioned in such a way as to be readily accessible.

Fit the plug (8 Fig. 4) into the switch socket (9 Fig. 4).

The plug must only be replaced by professionally qualified and authorized personnel, and the new plug must comply with current national safety standards.

If the appliance comes supplied without a plug and you wish to connect it permanently to the power supply, prepare an omnipolar circuit-breaker, with a

contact-opening gap of not less than 3 mm, in accordance with national safety standards currently in force. This switch must be equipped with fuses, with the associated residual current device positioned in such a way as to be readily accessible. This operation must be carried out by a specialized technician.



Make sure that you fully uncoil the power supply cable and check that it is not crushed in any way.



Should the supply cable be damaged, it must be replaced by a specialized technician using a special cable available from the manufacturer or from the Technical Service Centers.

## **5.4 CONNECTION TO THE WATER MAIN**



The appliance must be only be supplied with cold water for human consumption (drinking water).

The operating pressure must be between 0.1 and 0.6 MPa.

The appliance must be connected to the water main by professionally qualified personnel in accordance with the manufacturer's instructions.



A tap must be installed between the water mains and the feed pipe of the appliance, so that the water supply may be shut off if necessary.

Where the feed water is particularly hard, you are advised to install a softener. Any solid particles (e.g. sand) may be eliminated by installing a mechanical filter, which must be periodically inspected and cleaned.

**These devices must comply with the standards in force in the country of use.**



Never turn the water supply tap off when the appliance is working.

#### **5.4.a FILLING WITH WATER (Fig. 5)**

Insert the special seals provided (13) in the two threaded ring nuts of the water feed pipe (11) supplied with the appliance.

Without exerting excessive force (otherwise the unions could crack), firmly tighten one of the threaded ring nuts on the outlet of the solenoid valve located in the rear of the appliance. The other threaded ring nut must be screwed to the water tap (10); this too must be provided with a thread.

#### **5.4.b DRAINAGE (Fig. 5)**

Fix the water drainage pipe (14 Fig. 5) in the housing provided on the rear of the appliance. Make sure that:

- The pipe is a hose.
- The internal diameter is 22 mm, as required.
- The water drainage hose is not throttled at any point throughout its length.
- The drainage hose slopes downwards by at least 15%.

It is advisable to drain the water straight into an open drain trap.

### **6 START-UP**

#### **6.1 CLEANING INTERNAL PARTS**

The appliance has already been cleaned in the factory. However, you are advised to wash the internal parts again before using the appliance. Make sure that the power supply cable is unplugged before carrying out the above cleaning operation.

For cleaning operations in general, including subsequent ones, use an ordinary detergent for washing dishes or a solution of water and vinegar. Rinse thoroughly with plenty of cold water and eliminate any ice that may have been produced during the first few minutes.

It is advisable to avoid using abrasive detergents or powders, since these might damage the finish. (For further information regarding cleaning of internal parts, refer to Point 9.3 of this Instruction Manual.)

#### **6.2 START-UP (Fig. 6)**

After the appliance has been correctly connected to the electric supply mains, to the water supply mains, and to the water drainage system, you can start it up as follows:

- a) Turn on the water supply tap 10 (Fig. 4).
- b) Switch on the power supply by means of the relative switch fitted during the installation phase.

For appliances that are connected permanently to the electricity main, turn on by means of the switch on the outside of the appliance, fitted during the installation phase.

Start by pressing the relative switch (15 Fig. 6) which will light up if provided with this function.

### **7 MAIN CAUSES OF OPERATING FAILURE**

Should the appliance fail to produce ice, before calling on the Authorized Technical Service Center, first check carefully that:

- the water supply tap (10, Fig. 4), fitted during the installation phase, has been turned on.
- electric power is reaching the appliance; the plug is properly inserted, the corresponding switch (9 Fig. 4) is in the "ON" position, and the push button (15 Fig. 6) is lighted up.

Furthermore:

- if there is excessive noise, make sure that the appliance is not touching furniture or sheet metal which can give rise to noise or vibrations;
- should any trace of water appear, check the drain hole of the container to ensure that it is not clogged, that the water fill and drain pipes are correctly connected and are not throttled or damaged.
- make sure that the temperature of the air or water does not exceed the installation limit values.
- make sure that the water inlet filter is not clogged.

If the fault still persists after the above inspections have been made, turn off the electric power source by means of the switch fitted during the installation phase, pull out the plug from its socket, turn off the

tap connecting the appliance to the water main, and contact the nearest Authorized Technical Service Center.

To obtain a faster and more efficient reply when you call the Center, state the model of the appliance precisely, together with its serial number or manufacturing number. This information is given on the serial N° plate (Fig. 1) affixed to the rear of the appliance and on the cover of this Instruction Manual.

## 8 OPERATION

The appliance has a probe (16 Fig. 7) in the ice container.

When the ice reaches the probe, a thermostat automatically stops ice production.

When ice is taken from the container, the thermostat will automatically reactivate ice production, thus creating a new supply of flaked-ice.

## 9 MAINTENANCE

### 9.1 CLEANING THE SOLENOID VALVE FILTER

 At least every two months, clean the filter (17 Fig. 8) located on the water inlet solenoid valve, proceeding as follows:

- Switch off the electric power supply by means of the switch (9 Fig. 4), fitted during installation, and disconnect the plug of the appliance from its socket.
- Shut off the water supply by turning the tap (10 Fig. 4) fitted during installation.
- Unscrew the threaded ring nut (11a Fig. 8) of the water feed hose, located at the outlet of the solenoid valve at the rear of the appliance.
- Using a pair of pliers, remove the filter (17 Fig. 8) from its seat without damaging the water feed pipe connector.
- Place the filter under a strong jet of water to remove residue, but replace the filter if it is excessively dirty.

After having carried out the cleaning operations, refit the filter and hose pipe taking the necessary precautions described earlier in the Instruction Manual.

**When the operations have terminated, turn on both the electricity supply and water supply.**

### 9.2 AIR-COOLED MODELS

For air-cooled models, it is very important to keep the finned condenser clean.

Have the finned condenser cleaned at least once every two months by an authorized Technical Service Center, which can include this operation in the scheduled maintenance program.

### 9.3 CLEANING AND SANITIZING THE ICE TRAY (Fig. 9)

 **All cleaning operations must be carried out only after the electric power and water supplies have been disconnected, as described previously.**

Open the door (18) located on the front of the appliance.

This allows you to access the ice box (Fig. 9). Use a sponge to remove any sediment that may have collected on the bottom of the ice-box.

For cleaning, use an ordinary dish-washing detergent or a solution of water and vinegar. To eliminate scaling, use a soft plastic-bristle brush and a sponge.

Avoid using abrasive detergent or powders, which may damage the finish.

To obtain a sanitizing effect, repeat the above cleaning operations using a suitable solution, such as one of those used for disinfecting baby feeding bottles.

**When the cleaning and/or disinfecting operations have been completed, rinse thoroughly with plenty of cold water and eliminate any ice that may have been produced during the first few minutes.**

Complete sanitizing can only be carried out only by the Authorized Technical Service Centers, and must be done regularly depending on the conditions of use of the appliance, the chemical and physical features of the water, and after every period in which the appliance has remained at a standstill for any length of time.

You are advised to ask your dealer to draw up a scheduled maintenance contract that will cover the following:

- cleaning the condenser
- cleaning the filter located on the water inlet solenoid valve
- cleaning the ice-box
- checking the charge of coolant gas
- checking the operating cycle
- sanitizing the appliance.

#### 10 PERIODS AT A STANDSTILL

If you do not intend to use the appliance for a certain period of time, proceed as follows:

- Switch off the electric power source by means of the switch fitted during installation, and remove the plug of the appliance from its socket.
- Shut off the water supply by turning off the tap fitted during installation.
- Carry out all the operations envisaged for scheduled maintenance of the appliance.

*The Manufacturer declines all liability for any inaccuracies in this Instruction Manual due to printing or transcription errors. The Manufacturer also reserves the right to make any modifications to the products that may be necessary or useful, also in the interests of the user, without impairing the products' essential features of functionality and safety.*

