



Catalogue
CATERING
Chapter
COOKING

Model
FT-G910 C L LPG 230V 1N

19036556

14/12/2018

GAS FRY-TOP CHROMIUM PLATED, FT-G910 C L
Fry-top plates or hot plates are designed to grill a large amount of products. They are particularly fast and heat is evenly distributed. Thanks to their high power, they reach working temperature in a short time.
Chrome coated plates can be used for any type of food. They are specially recommended for fish and sea food or for fried recipes with egg.
2 mm stainless AISI-304 steel top with rounded edges for easy cleaning. Laser cut and automatic welding for a perfect side to side adjustment of modules with square angle finish.
The hot plate is made of 20 mm thick mild steel.
Hot plate integrated into the embedded top. Easy to clean thanks to the rounded edges and embedded construction. Minimum edge radius 3.5 mm for easier cleaning.
Plate and lodging made according to EN-202-3 standard for materials in contact with food.
The plate is slanted forward for an easier collection of fat and liquids.
Fitted with a cooking fat drainage hole and removable collecting tray. Smooth plate surface.
50 micron thick chrome coated plate.
Chrome surface stops food flavour to be transferred from one type of food to another.
The chromed surface maintains the temperature and prevents heat irradiation and dispersion. This reduces cooking time, temperature recovery time and improves the working environment conditions.
Useful heating surface: 47 dm². Dimensions: 735 x 640 mm.
Heating by means of two double branch gas burner.
The independent control knob for each burner allows to work with half or the whole plate.
Thermostat for temperature control (between 100 and 300°C).
The thermostat control allows a more accurate adjustment of the plate cooking temperature for each type of product.
Safety thermostat.
Electronic ignition. Access tube for manual ignition.
Optional three-piece anti splash removable shields for easy cleaning.
Water-tight and protecting-support controls.
High temperature protector for the chimney made of enamelled cast iron.
Front access to components.
According to European standards for components and panels temperature, efficiencies and combustion, and sanitary regulations (EN-60335 and EN-203)
IPX5 grade water protection equipment.

DIMENSIONS

X Width	800 mm	X Gross width	840 mm
Y Depth	930 mm	Y Gross depth	1022 mm
Z Height	290 mm	Z Gross height	535 mm
Net Weight	128,0 kg	Gross Weight	149,0 kg
Net volume	0,283 m ³	Gross volume	0,459 m ³

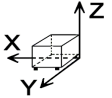

ELECTRICITY TECHNICAL SPECIFICATIONS

Electric power	0,100 kW
Voltage	230V - 1N
Amperage	2A
Electric frequency	50/60Hz

GAS TECHNICAL SPECIFICATIONS

Gas type	LPG
Gas power	18,50 kW
Gas consumption	1,440 kg/h
Regulated	LPG G30/G31 28-30/37 mbar NG G20/G25/G25.1 20/25/25 mbar



Catalogue
CATERING

Chapter
COOKING

Model
FT-G910 C L LPG 230V 1N

19036556

14/12/2018

FT-G905

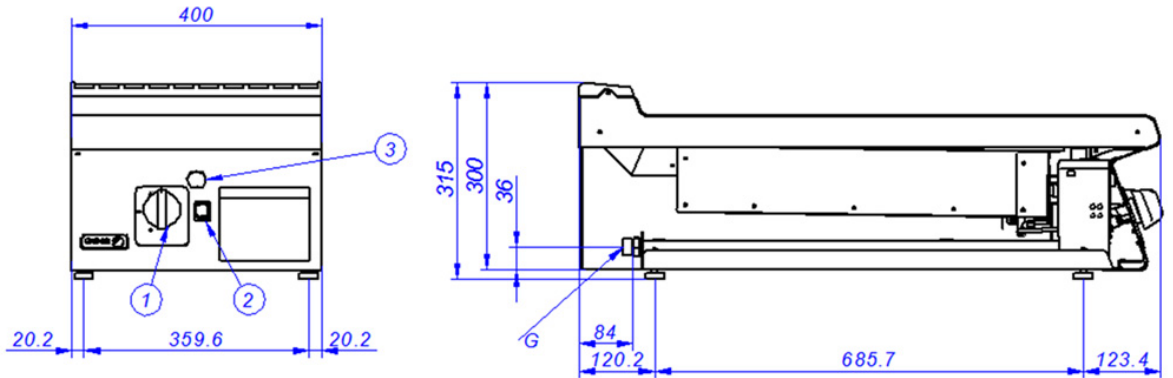

FT-G910

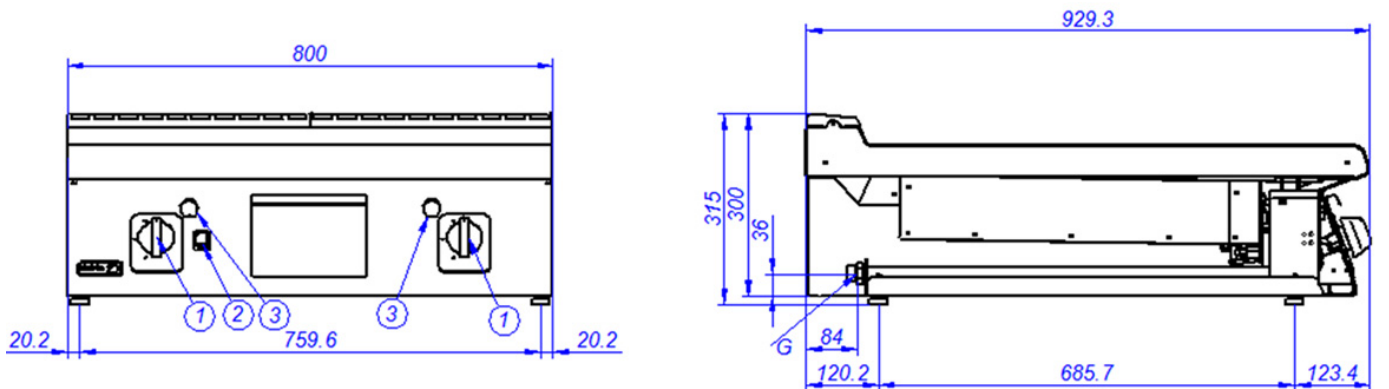

- G. Entrada de Gas
- 1. Válvula de gas
- 2. Pulsador tren de chispas
- 3. Orificio de encendido manual

- Gas Inlet
- Gas valve
- Piezoelectric ignitor
- Manual ignition hole