



Catalogue
CATERING
Chapter
COOKING

Model
FTG7-05 L LPG

19005269

30/05/2019

GAS FRY-TOP, FTG7-05 L
Made of stainless steel.
Smooth hot-plate.
Surface area: 20 dm². 34 x 55 cm.
Tubular burner in stainless steel with pilot.
Thermostat control of the hot-plate temperature 120 C° -310 C°.
Fat collector under the grill.

DIMENSIONS



X Width	350 mm	X Gross width	390 mm
Y Depth	775 mm	Y Gross depth	885 mm
Z Height	370 mm	Z Gross height	550 mm
Net Weight	41,0 kg	Gross Weight	50,0 kg
Net volume	0,100 m3	Gross volume	0,190 m3

ELECTRICITY TECHNICAL SPECIFICATIONS

Voltage	N/A
Electric frequency	N/A

GAS TECHNICAL SPECIFICATIONS

Gas type	LPG
Gas power	6,30 kW
Gas consumption	0,530 kg/h
Regulated	LPG G30/G31 28-30/37 mbar NG G20/G25/G25.1 20/25/25 mbar

CONNECTIONS TECHNICAL SPECIFICATIONS

Gas diameter 1	R.3/4"G
----------------	---------



Catalogue
CATERING

Chapter
COOKING

Model
FTG7-05 L LPG

19005269

30/05/2019

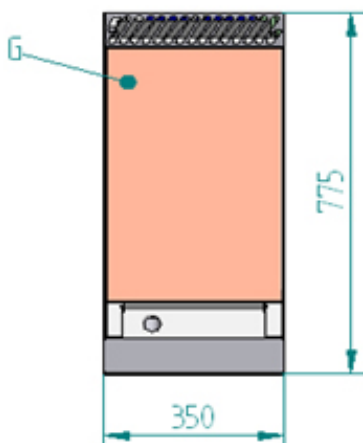
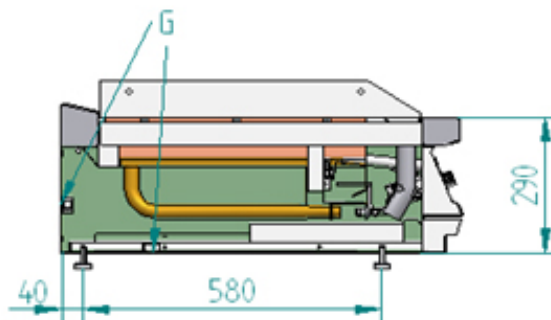
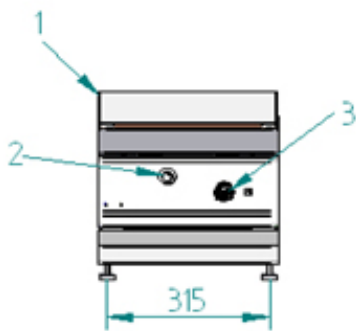

G: Entrada de gas
1: Plancha de asado
2: Orificio de encendido manual
3: Válvula de gas

G: Gas inlet
1: Grill plate
2: Manual ignition hole
3: Gas valve